

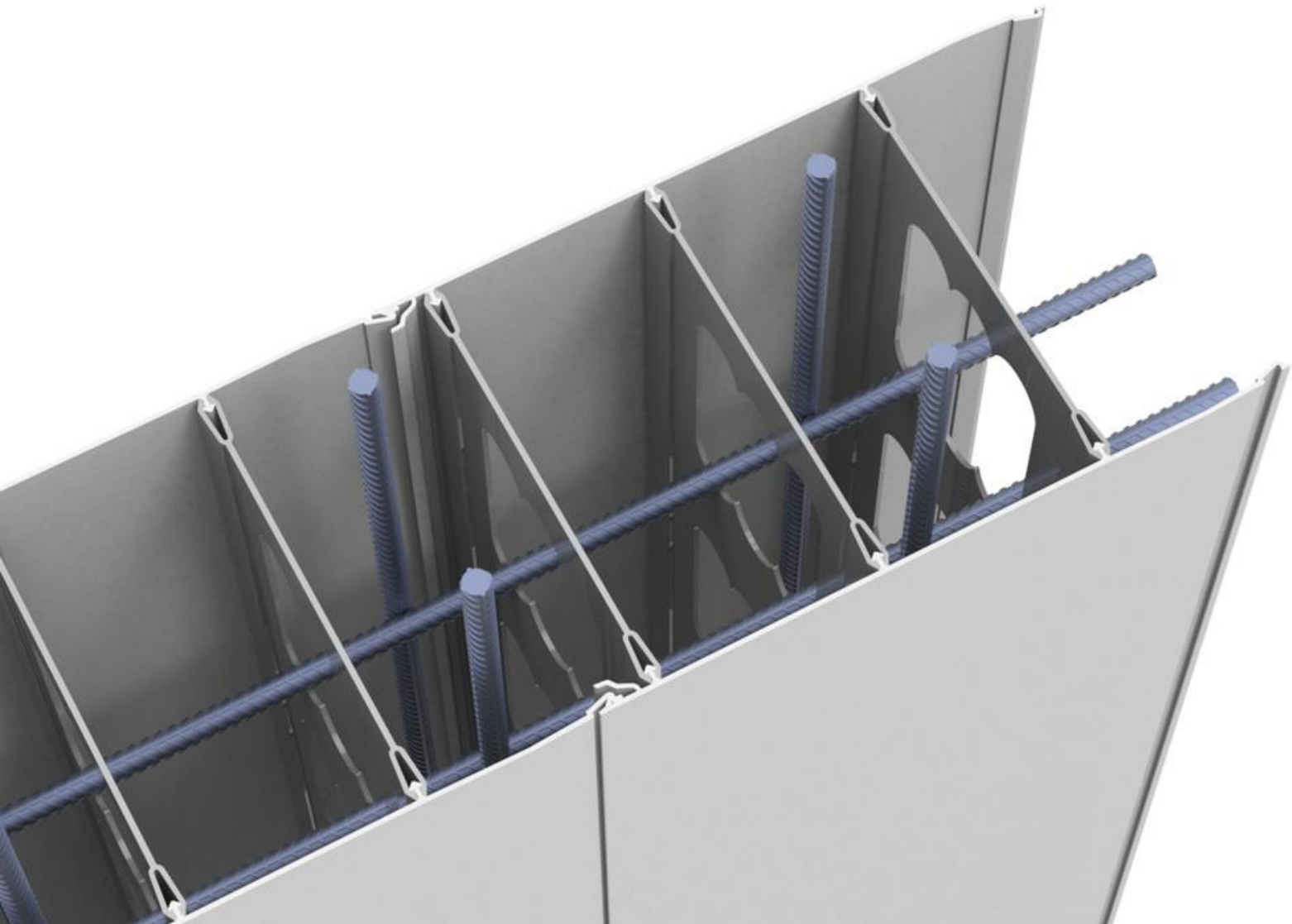

PERMAFORM

QUICK ► STRONG ► STRAIGHT



INSTALLATION MANUAL

V2.0 AUGUST 2019

Distributed by:
Auswood International
02 9792 8986

accounts@auswood.com.au
Unit 6, 4 Violet Street
Revesby NSW 2212

CONTENTS

1.	INTRODUCTION AND INSTALLERS LIABILITY	3
	1A. BULGING AND BLOW-OUTS	3
2.	SAFETY	4
3.	DELIVERY AND UNLOADING	5
	3A. PACKAGING	5
	3B. ACCEPTANCE	5
	3C. UNLOADING	6
	3D. IDENTIFYING PACKS	6
4.	SET-OUT	7
5.	INSTALLATION	12
	5A. BOTTOM TRACKS AND STARTER BARS	12
	5B. FIRST PANEL	14
	5C. BRACING AND PROPPING	14
	5D. PANEL-TO-PANEL	17
6.	SETDOWNS AND PLACING HORIZONTAL REINFORCING BARS	17
7.	ENDING A WALL	19
8.	IRREGULAR CORNERS	20
9.	OPENINGS – WINDOWS, DOORS AND PENETRATIONS	21
10.	VERTICAL REINFORCING BARS	24
11.	PRE-POUR	26
	11A. PRE-POUR CHECKS	26
	11B. TEMPORARY PATCHING	26
	11C. RECOMMENDED CONCRETE QUANTITY	27
	11D. SUGGESTED CONCRETE MIX	27
12.	POUR SEQUENCE	28
13.	POUR PROCEDURE	29
14.	VIBRATING	30
15.	POST-POUR	30
	15A. CLEAN UP	30
	15B. PATCHING	30
	15C. REMOVING PROPS AND BRACING	31
	15D. CHECK FOR VOIDS	31
	15E. VOID RECTIFICATION PROCESS	

TABLES, DETAILING AND DIAGRAMS

TYPICAL HANDLING WEIGHTS	4
TYPICAL DELIVERY PACK DIMENSIONS	6
110MM PROFILE - EXAMPLE PANEL ARRANGEMENT	8
155MM PROFILE - EXAMPLE PANEL ARRANGEMENT	9
200MM PROFILE - EXAMPLE PANEL ARRANGEMENT	9
250MM PROFILE - EXAMPLE PANEL ARRANGEMENT	10
STARTER BAR PLACEMENT EXAMPLES	13
BRACING PROPPING DETAILS AND DIAGRAM	15
PROPPING FOR LOW WIND	16
PROPPING FOR HIGH WIND	16
HORIZONTAL REINFORCING BARS	18
PROPPING FOR WALL ENDINGS	19
FORMING OBTUSE AND ACUTE ANGLES	20
FORMING OPENINGS AND PENETRATIONS	21
VERTICAL REINFORCING BARS	24
REINFORCEMENT CONFIGURATION EXAMPLES	25
CONCRETE QUANTITY	27
POUR SEQUENCE	28
CONCRETE PUMP LOCATION	29

APPENDICES

• TECH-SPECS DATASHEET
• MSDS SAFETY DATA SHEET
• TERMS AND CONDITIONS OF SALE
• PRODUCT CATALOGUE
• PRE-POUR CHECKLIST

Date: August 2019

Version: 2.0

Revisions:

Void rectification process; Tech-specs datasheet; pre-pour checklist; formatting and images

Disclaimer: To be read in conjunction with PERMAFORM INTERNATIONAL P/L TERMS AND CONDITIONS (found in appendices) and 1. Installers' liability. The detailing in this document are to be treated as general guidance and not project specific.

INTRODUCTION AND INSTALLERS' LIABILITY

PERMAFORM is a Polyvinyl Chloride (PVC) permanent formwork wall system for structural elements which is concrete filled.

The installation of PERMAFORM should only be undertaken by persons with building industry knowledge and who have a trade background.

While every effort has been taken to make this guide as comprehensive as possible, it is not feasible to produce a document that pre-empts every detail and circumstance that could arise in the process of installing PERMAFORM. This document is produced solely as a guide. It is the responsibility of the installer to read and understand this manual thoroughly.

To ensure successful installation of PERMAFORM, it is critical that builders and trades people follow the recommended practises within. Installers of PERMAFORM should either be - or be supervised by – those with at least conventional form-working, carpentry or foreman qualifications to adhere to safe construction practices.

These include the requirements of the applicable local authority's Occupational Health and Safety rules and building codes of practice for form-working and concrete steel placement.

As the manufacturer, PERMAFORM International accepts no liability for any consequences whatsoever that arise as a result of the use of PERMAFORM on any site or in any application. By undertaking to install PERMAFORM, the persons doing so acknowledge they have the skills, knowledge, experience and ability to safely, efficiently and professionally install PERMAFORM; thereby indemnifying PERMAFORM International from any claim that arises from such installation except to make good or replace (at their discretion) any product that has failed as a result of defective materials or manufacture.

1A. BULGING AND BLOW-OUTS

During and after pouring concrete, bulging or 'blow-outs' can occur at panel joints if the ribs within the panels have been damaged.

It is the responsibility of the installer to ensure no PERMAFORM ribs or panels are damaged prior to pouring. This manual includes a pre-pour checklist for installers to help mitigate this risk. As the manufacturer, PERMAFORM International accepts no responsibility for installation issues that may occur on the construction site after acceptance of the product. (Refer Terms and Conditions of Sale – in the appendices.)

2 SAFETY

Installers of PERMAFORM must adhere to all safety standards normally required of formworking and concreting trades.

If the product needs to be cut or drilled on-site, installers must wear appropriate PPE (Personal Protective Equipment) including dust-proof respirators and protective eyewear. Appropriate, safety-tagged cutting tools – drills, grinders with steel blades and circular saws – must be used.

Depending on profile width and length, panels typically weigh between 15kgs and 18kgs per square metre.

Panels up to 20kgs can be safely handled by one person, 20kgs – 40kgs should be handled by two people.

Always follow safe manual handling practices.

TYPICAL WEIGHTS FOR HANDLING	
Profile	Weight per square metre
110mm	14.7 kg
150mm	15.8 kg
200mm	16.8 kg
250mm	17.8 kg

PERMAFORM panels do not require any specific PPE. Gloves are not essential, however on sites where mandatory, gloves with rubber fingers and palm infills will reduce the risk of slipping.

PERMAFORM should not be installed in high-wind conditions.

Please refer to PERMAFORM’s MSDS in the appendices.



PERMAFORM'S MSDS

DELIVERY AND UNLOADING

3A. PACKAGING

PERMAFORM is typically delivered to site in packs – by either a rigid or semi - packaged in timber frames, nailed together and secured by steel strapping.

Depending on profile widths ordered, packs may contain from 12 to 27 panels.

Accessories are packed carefully on an order-by-order basis and will typically arrive with timber spacings to best fit the configuration of the rest of the order.

The number of panels and configuration in each pack – and on each truck - will vary depending on the profile width and length and accompanying accessories.

3B. ACCEPTANCE

Particular care must be taken by the client (or representative) to ensure the unloading and storage of the product on site does not incur damage to the product. Clients are required to sign a Proof of Delivery Docket upon receipt of their order confirming the order has been received in good condition.

Once products are inspected, signed for and accepted on-site – PERMAFORM International is indemnified from any claim that arises. This is particularly important as installing damaged products can lead to blow-outs, bulging and other defects which PERMAFORM cannot accept liability for once acceptance of the product is signed for.



Truck	Packs	Panels (up to)	M ² of product
Rigid	8	120 panels	108
Semi	16	240 panels	216

3C. UNLOADING

Prepare an appropriately sized space onsite for bundles to be unloaded to (refer to dimensions guide below). The space should be a level surface, clear of debris and hazards.

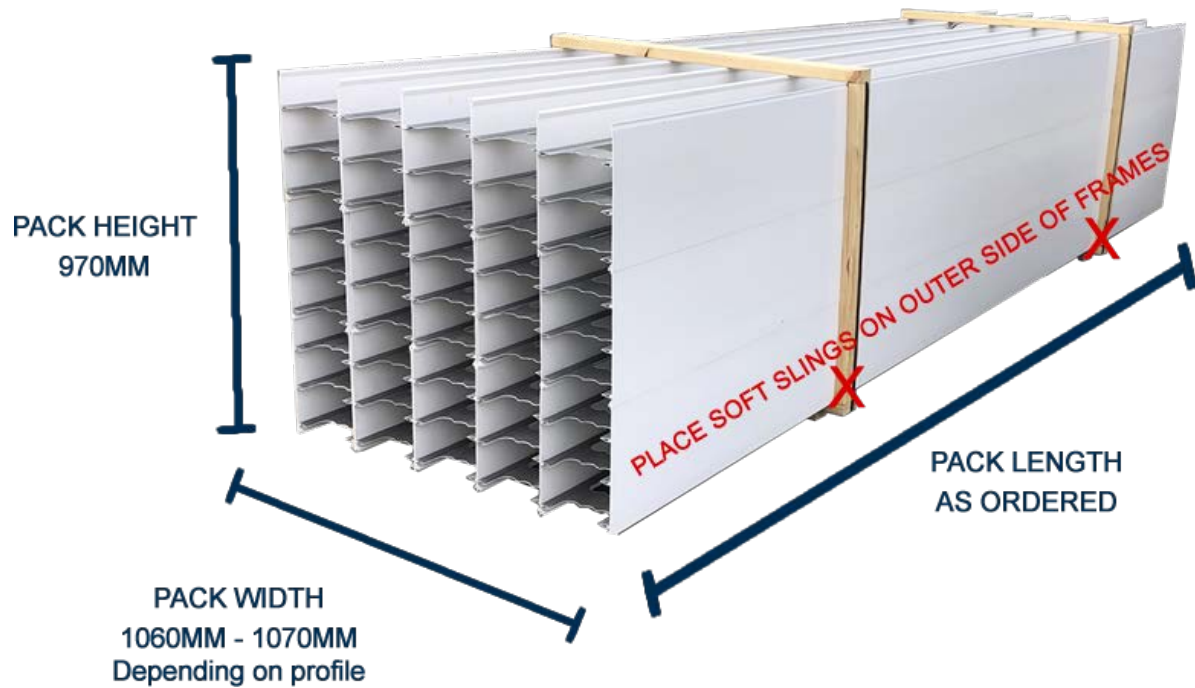

Packs can be unloaded by Hiab, forklift or crane. Lift no more than two bundles at a time. If lifting by Hiab or crane, strap crange soft slings to the bottom outside faces of timber frames to minimise risk of damaging panels.

Packs should be stacked no greater than two packs high with spacers. Spacers should be at four (4) points for even distribution of dead weight, particularly to prevent distortion in extreme heat.

Packs with stock measuring greater than 5m in length should be lifted one pack at a time.

The licensed forklift driver/crane operator must ensure packs are placed carefully on the ground and not dropped from a height.

3E. IDENTIFYING PACKS

The contents of each pack delivered is clearly labelled on the pack.



DESCRIPTION	QTY

QA CHECK Date:

4 SET OUT

Using the pins and markings provided by the surveyor, ensure the walls are clearly and accurately set out. The builder should be responsible for this – and should sign-off on the set out.



It is important to consider the wall layout and to establish the best starting point and sequence in which to proceed with installation of panels, to ensure that the most working space possible is kept clear.

Consideration should also be given to the positioning of braces to provide the best results and also to minimise the restriction of free movement of trades around the site.

If walls are to be filled from a mobile scaffold, run the braces in a logical way that leaves one face of each wall clear.

Refer to the 'Example panel arrangement' guides in this chapter to assist in planning your site set-out and forming elements like corners.



110MM EXAMPLE PANEL ARRANGEMENT

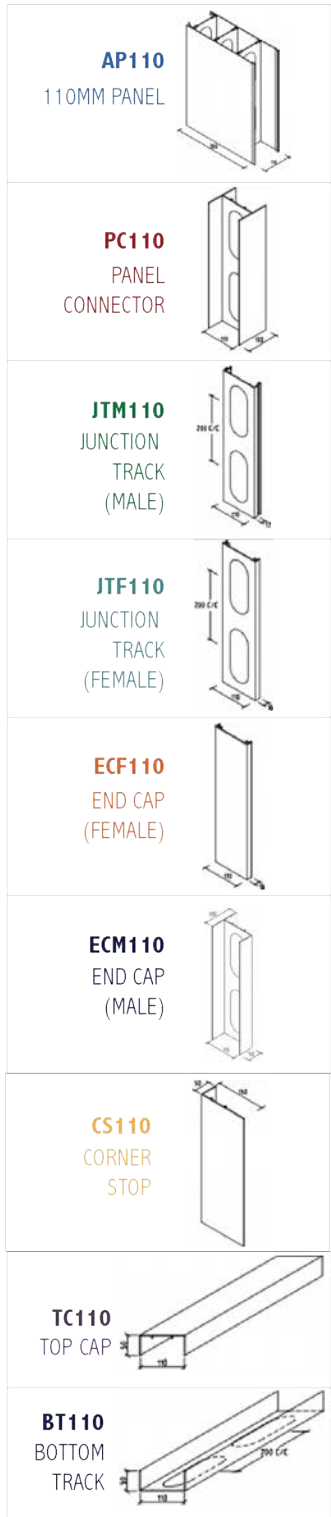
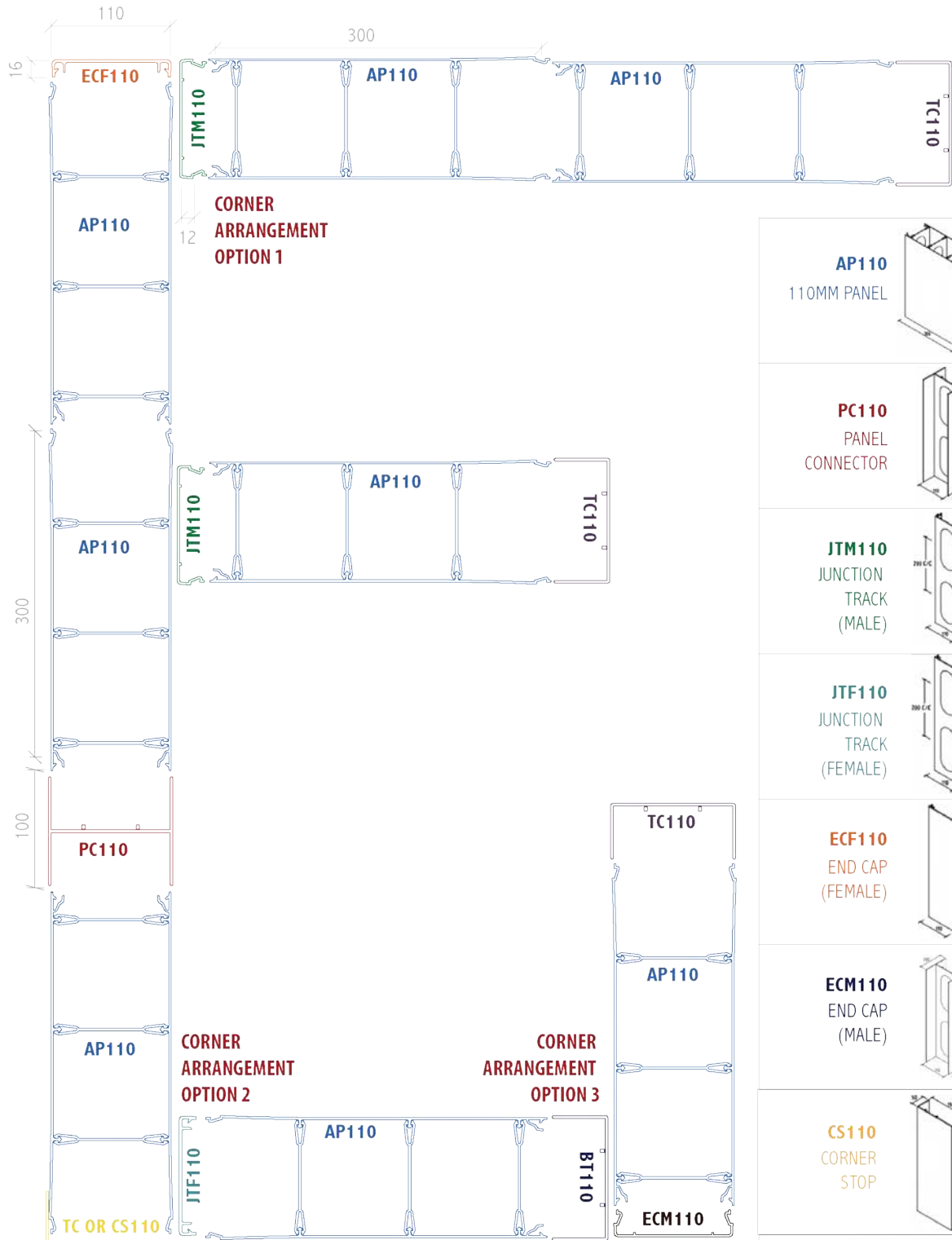

155MM EXAMPLE PANEL ARRANGEMENT

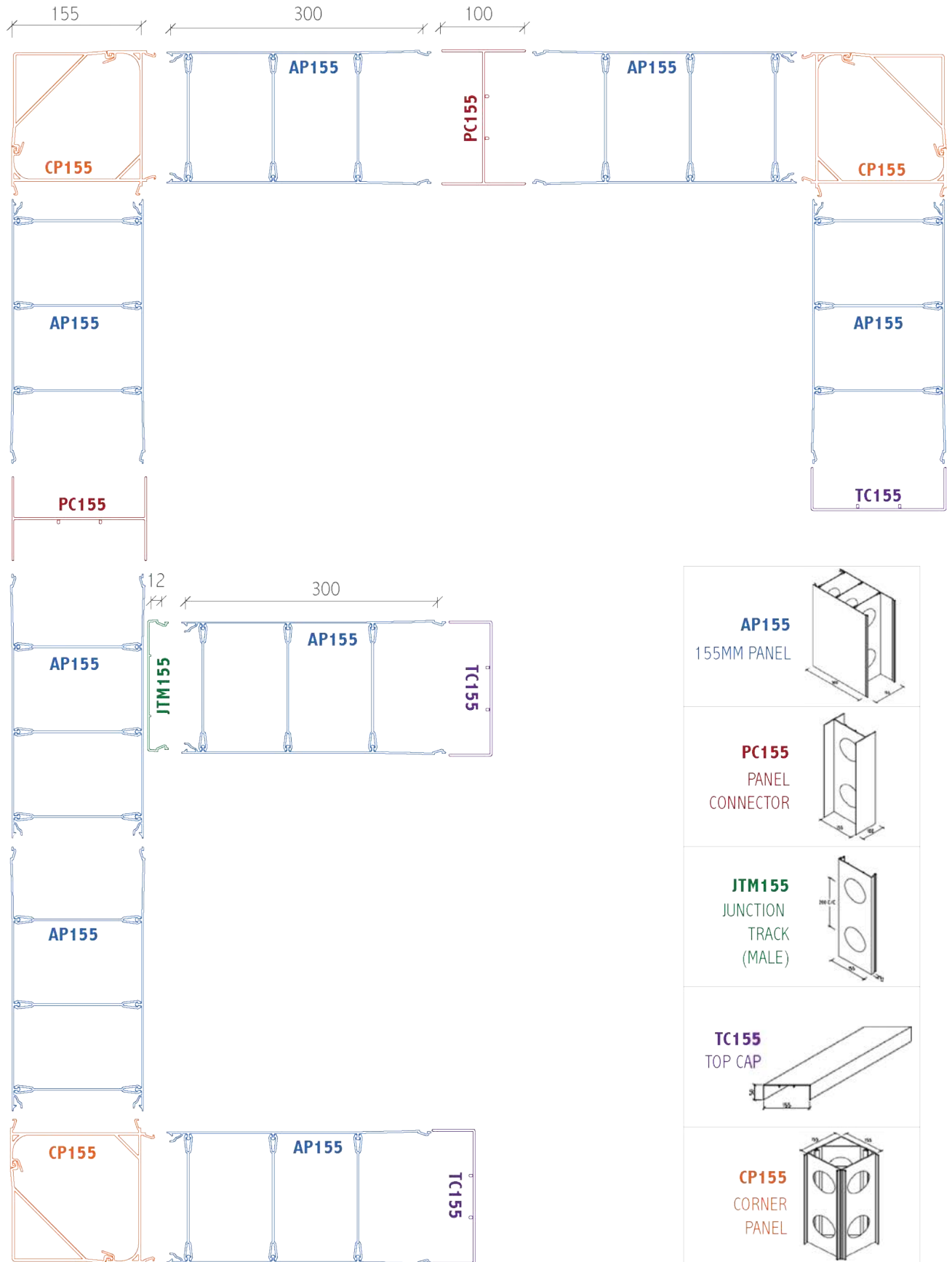



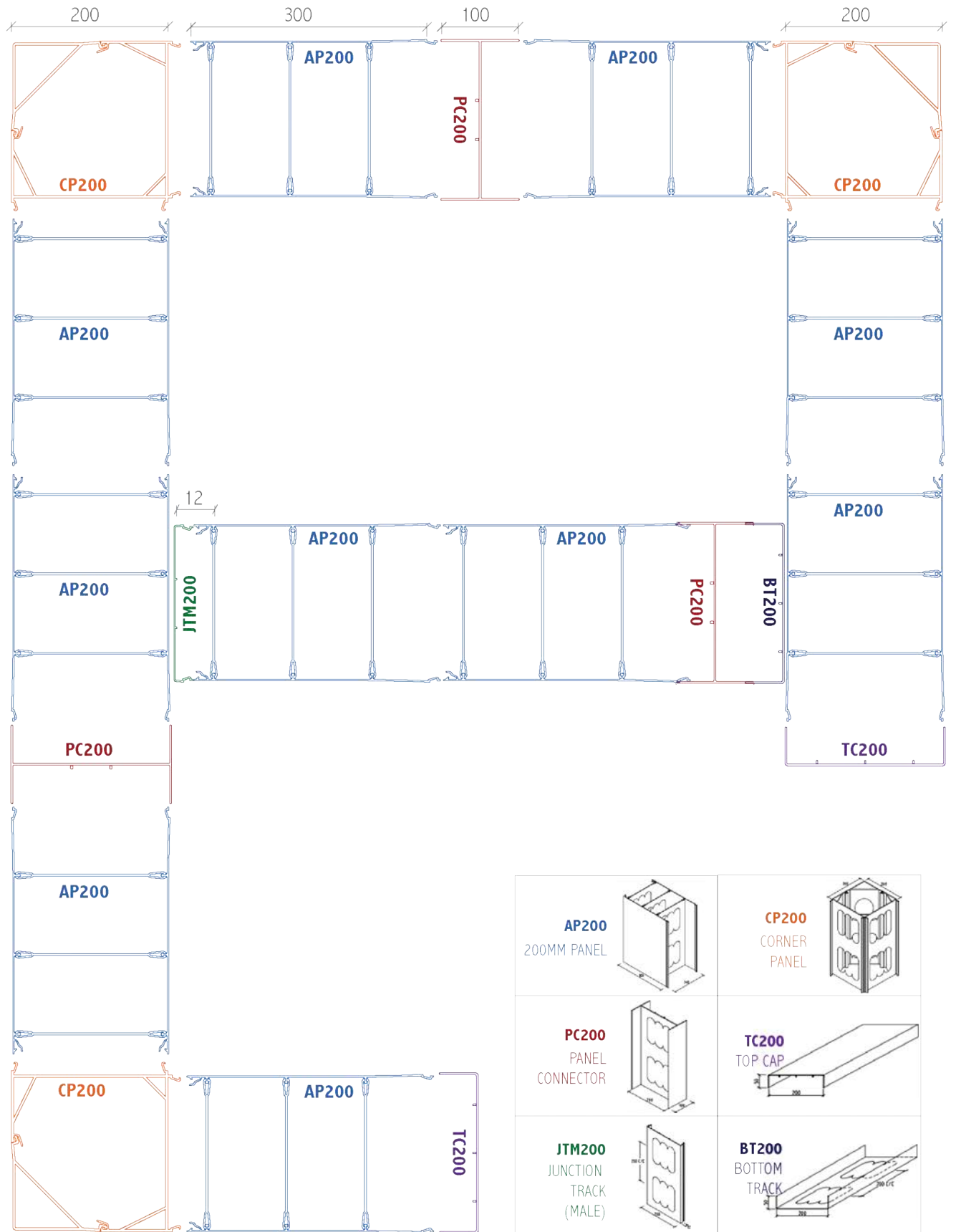

<p>AP155 155MM PANEL</p>	
<p>PC155 PANEL CONNECTOR</p>	
<p>JTM155 JUNCTION TRACK (MALE)</p>	
<p>TC155 TOP CAP</p>	
<p>CP155 CORNER PANEL</p>	

200MM EXAMPLE PANEL ARRANGEMENT

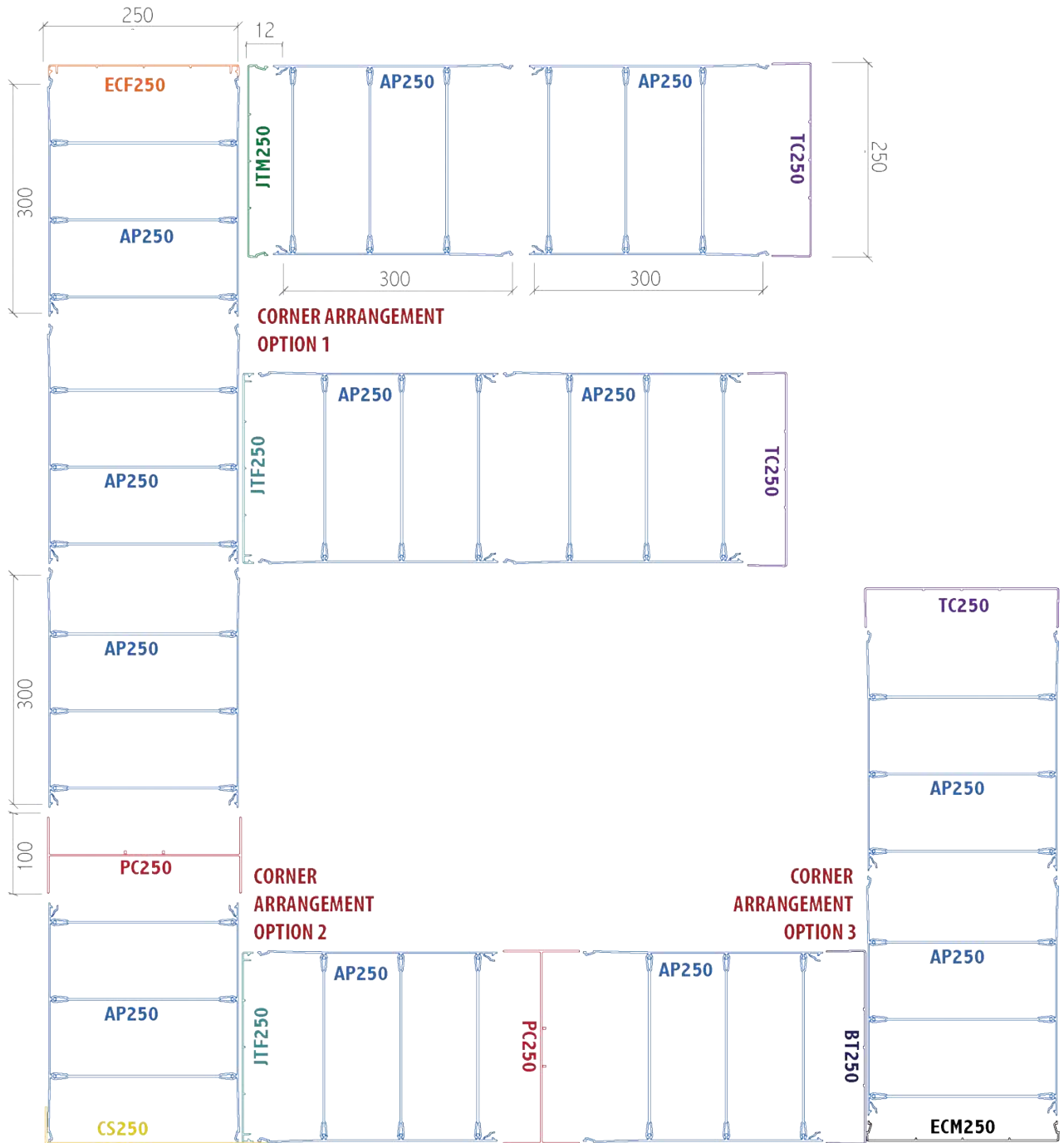

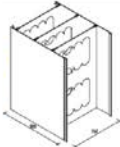
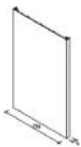
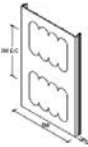
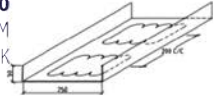
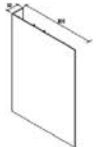
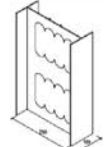
250MM EXAMPLE PANEL ARRANGEMENT

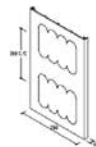

<p>AP250 250MM PANEL</p> 	<p>ECF250 END CAP (FEMALE)</p> 	<p>JTM250 JUNCTION TRACK (MALE)</p> 	<p>BT250 BOTTOM TRACK</p> 	<p>CS250 CORNER STOP</p> 
<p>PC250 PANEL CONNECTOR</p> 	<p>ECM250 END CAP (MALE)</p> 	<p>JTF250 JUNCTION TRACK (FEMALE)</p> 	<p>TC250 TOP CAP</p> 	

5 INSTALLATION

5A. BOTTOM TRACKS AND STARTER BARS

Before beginning the installation of Bottom Tracks, ensure the concrete footing/slab is clear, flat and free of debris.

Using pins/markings provided by the surveyor, ensure that the walls are clearly and accurately set out.



If specified, waterproofing detail must be applied in conjunction with the Bottom Track on all external walls and any portion of the wall that separates or adjoins wet areas.

Place each starter bar as specified by structural engineer's design. See overleaf for example starter bar positions.



Angles or lengths of timber can be used in place of Bottom Tracks to guide the wall panels.

Fix Bottom Track in place using concrete nails. Apply enough nails to ensure the Bottom Track is securely fastened into the slab.

Cut the Bottom Track to accommodate fouling starter bars if required.

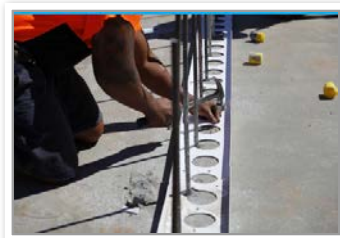
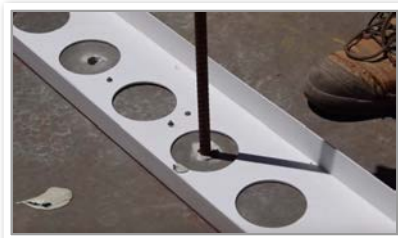

EXAMPLE STARTER BAR PLACEMENT

NOTE: THESE DETAILS ARE SUGGESTIONS ONLY.
STARTER BAR PLACEMENT SHOULD BE SPECIFIED BY THE STRUCTURAL ENGINEER.

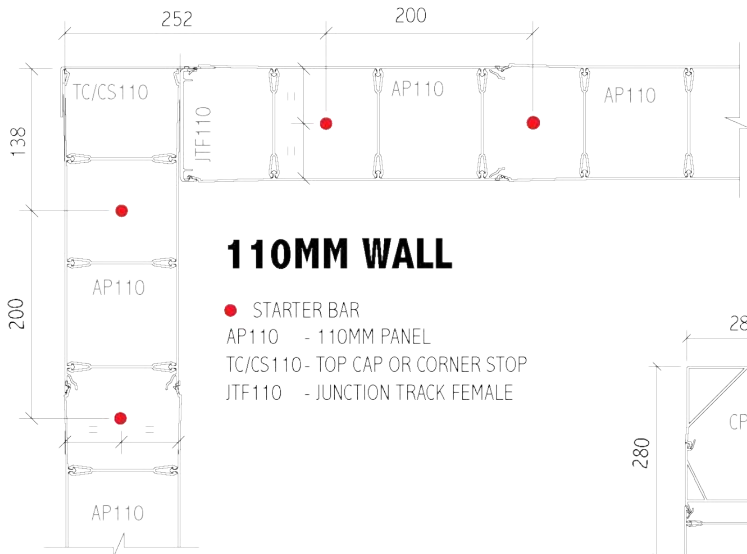

110MM WALL

- STARTER BAR
- AP110 - 110MM PANEL
- TC/CS110- TOP CAP OR CORNER STOP
- JTF110 - JUNCTION TRACK FEMALE

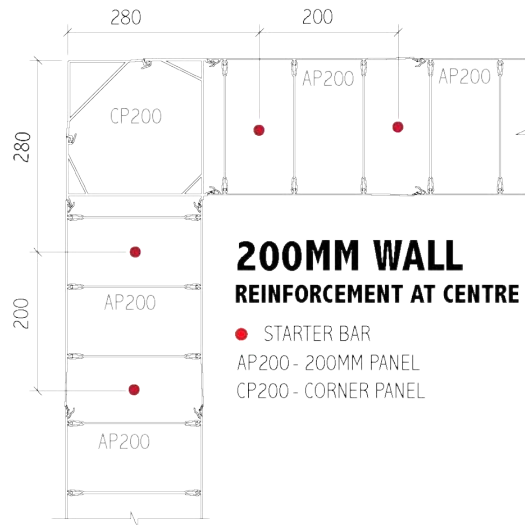

200MM WALL REINFORCEMENT AT CENTRE

- STARTER BAR
- AP200 - 200MM PANEL
- CP200 - CORNER PANEL

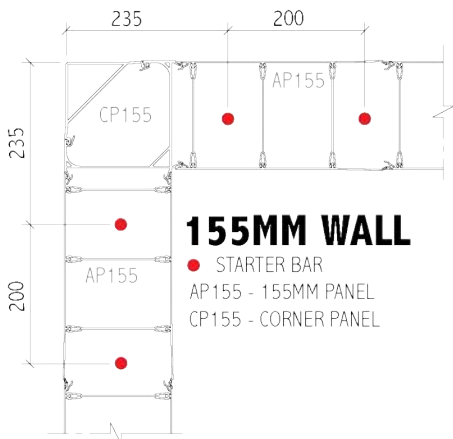

155MM WALL

- STARTER BAR
- AP155 - 155MM PANEL
- CP155 - CORNER PANEL

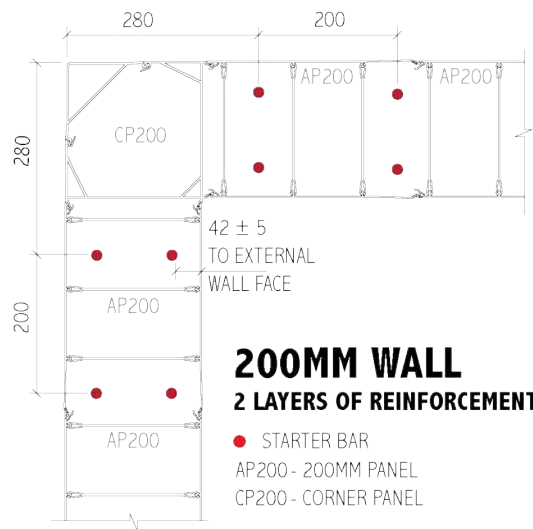

200MM WALL 2 LAYERS OF REINFORCEMENT

- STARTER BAR
- AP200 - 200MM PANEL
- CP200 - CORNER PANEL

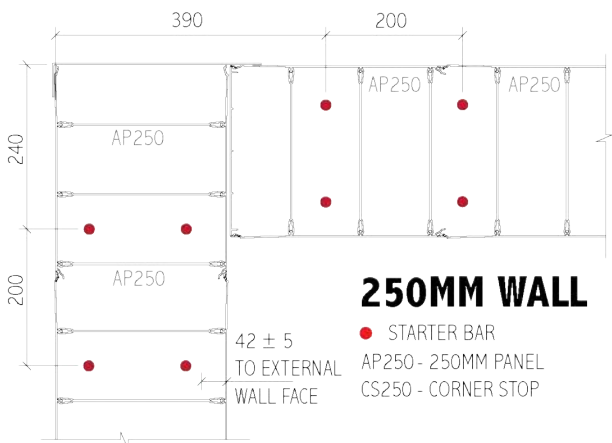

250MM WALL

- STARTER BAR
- AP250 - 250MM PANEL
- CS250 - CORNER STOP

5B. FIRST PANEL

It's recommended to start with a corner panel and plumb this from adjacent faces.

Working in a two-man team, adhering to safe manual handling procedures, lift the panel clear of the starter bars, align with the Bottom Track and lower into position within the track's upturned edges.

Should any of the starter bars foul on the ribs within the panel, the bars can normally be pushed/pulled clear of the rib and the panel successfully lowered as normal. Occasionally it may be necessary to lift the panel completely clear and bend the starter bar that is fouling to re-align them sufficiently for the panel to be easily lowered into position.

Brace the first panel using one screw per brace. The base of the brace is then fixed to the slab using an anchor style bolt.

The first panel is then plumbed with a spirit level or similar before the brace is fixed.

In some instances, there may be no slab to affix the brace base by bolt. In this case, it is recommended to use a steel peg driven through the brace base plate into the ground.

5C. BRACING AND PROPPING

Adjustable braces are recommended to be able to push/pull the top of the wall into alignment.

In situations where panels higher than 3.3m are being installed, or on sites known to be subject to wild wind conditions, it is the responsibility of the builder and the installers to ensure that the PERMAFORM panels are adequately braced to maintain their integrity until filled with concrete.

Along with the bracing, the top of the panels must also be secured with a timber strong back or steel angle (see diagram). These are to be screwed to the panel. One screw per panel is recommended.

Once the first panel is securely in place and plumbed, screw along the bottom track at 300mm centres. (Do not screw within 10mm of a panel joint).



ALWAYS INSTALL PANELS WITH THE HALF RIB HOLE TO THE BOTTOM. THIS IS NECESSARY FOR CORRECT ALIGNMENT OF ALL RIBS, PLACING HORIZONTAL REINFORCEMENT AND CONCRETE FLOW.

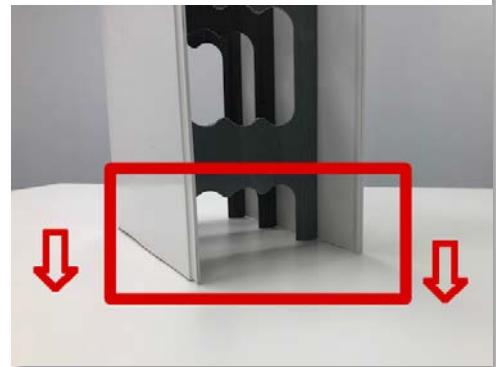

ONCE THE FIRST PANEL OF THE WALL IS IN PLACE, IT IS ESSENTIAL THAT THE PANEL IS SQUARE, STRAIGHT, PLUMB AND TRUE BEFORE FURTHER PANELS ARE INSTALLED.

BRACE TYPE	L1/L2 (M)	DESIGN CAPACITY
MINI	4.4 MAX	kN 15
STANDARD	6.8 MAX	kN 25

- THE PROPS WITH DESIGN CAPACITY NOTED ARE TO COMPLY WITH AUSTRALIAN STANDARDS
- DIMENSIONS QUOTED ARE BASED ON FULL EXTENSION OF BRACES
- LONG BRACES MAY REQUIRE KNEE BRACING - REFER TO SUPPLIER

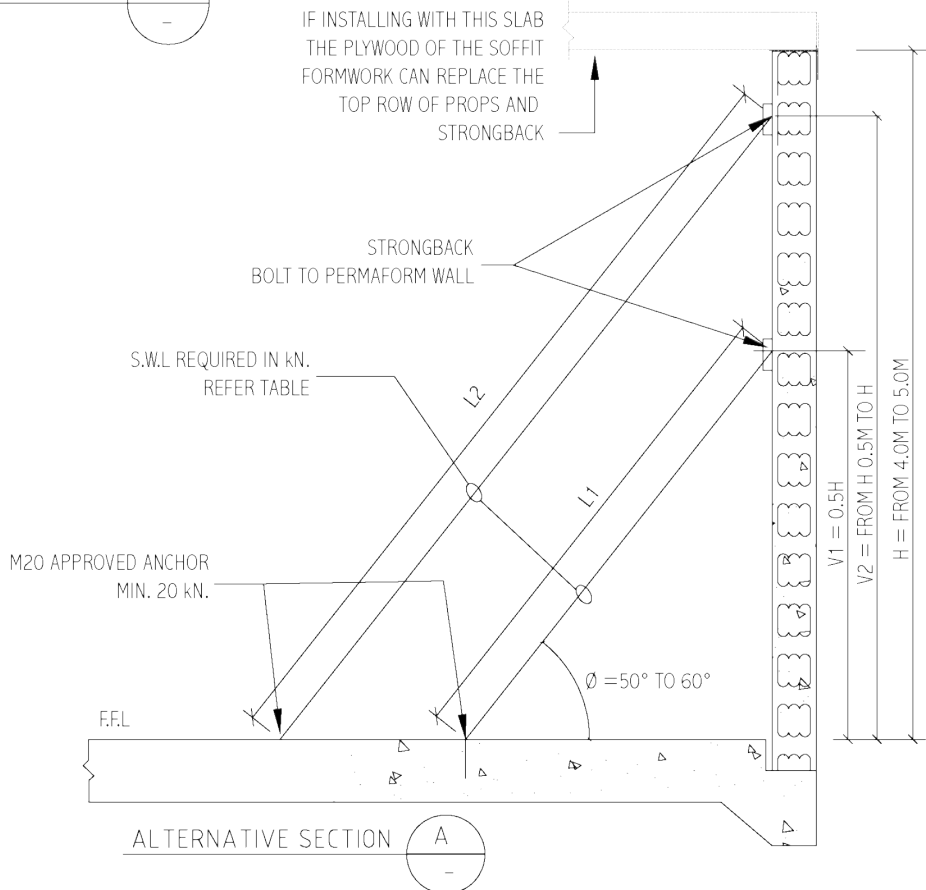
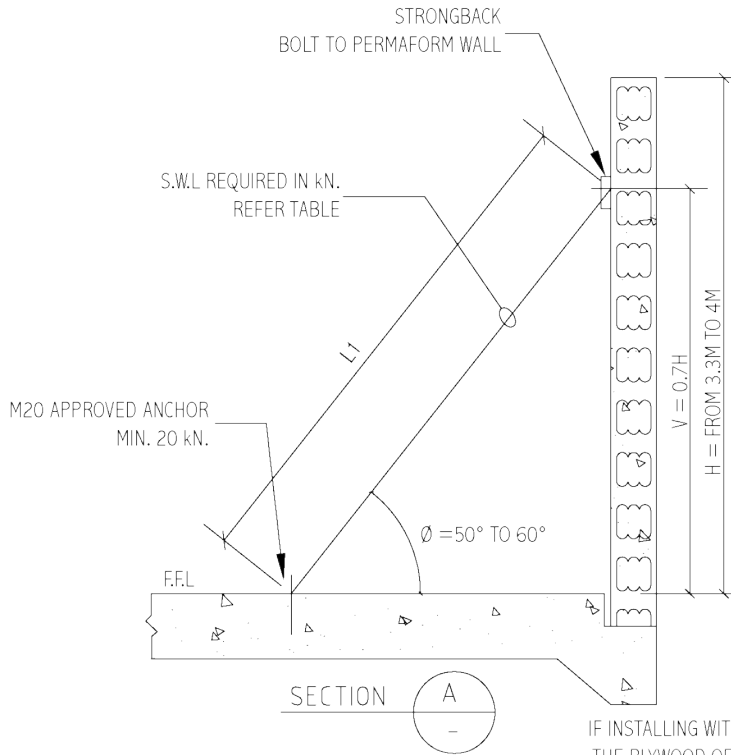

SUGGESTED PROPPING FOR LOW WIND / SUBURBAN / SHELTERED AREAS

PLEASE NOTE: DETAILS ARE FOR GUIDANCE PURPOSES ONLY. PROPPING SHOULD BE SPECIFIED BY ENGINEER AND SHOULD BE CALCULATED FOR SPECIFIC SITE CONDITIONS.

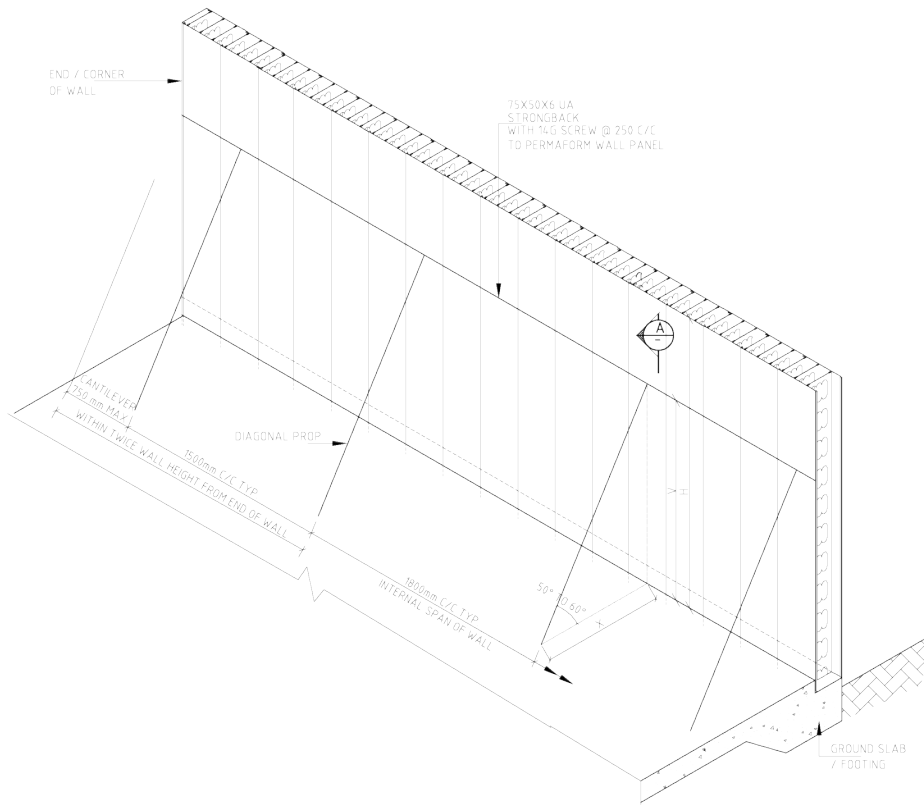

SUGGESTED PROPPING FOR OPEN RURAL AREAS AND SUBURBAN EXPOSED AREAS

PLEASE NOTE: DETAILS ARE FOR GUIDANCE PURPOSES ONLY. PROPPING SHOULD BE SPECIFIED BY ENGINEER AND SHOULD BE CALCULATED FOR SPECIFIC SITE CONDITIONS.

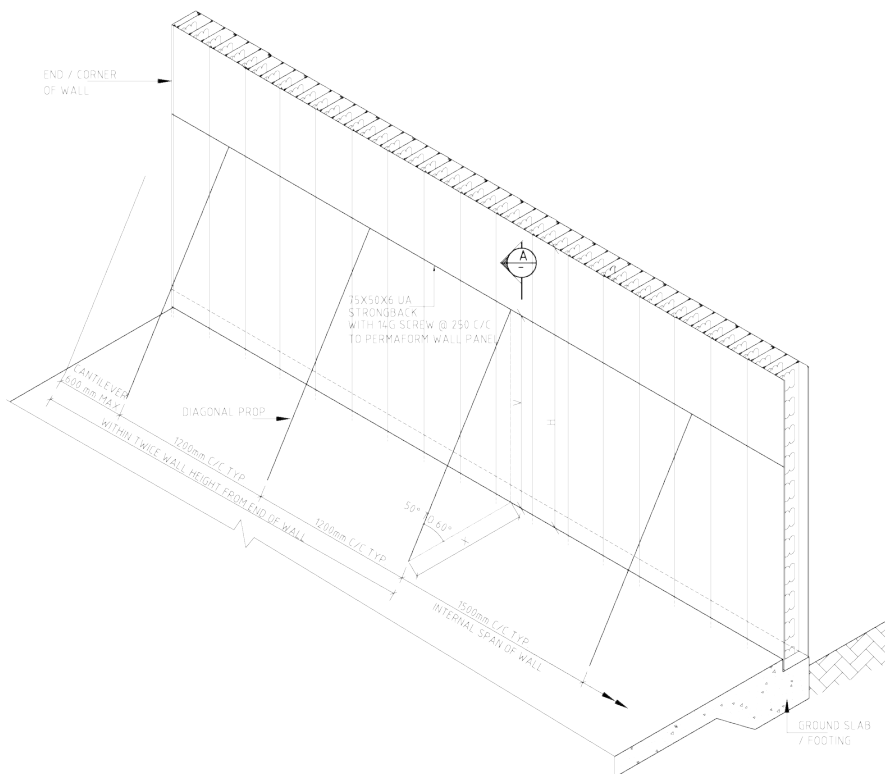

5D. PANEL-TO-PANEL

The next panel is now brought alongside the Bottom Track and lifted clear of the starter bars.

Place panels carefully to accommodate starter bars and other detail. Panels clip and slide into place and lock together with ease. Use a rubber mallet or similar for adjustment and persuasion to height and line.

Should any of the starter bars foul on the panels internal ribs, the bar can be adjusted by being pulled or pushed clear of the rib.

Repeat the process



Continue to place panel-to-panel, repeating the process of bracing and propping to ensure plumb – and screwing off at bottom tracks.

Ensure all internal rib holes are aligned with each other to ensure correct placement of horizontal reinforcing bars and free flow of concrete.



ALWAYS INSTALL PANELS WITH THE HALF RIB HOLE TO THE BOTTOM. THIS IS NECESSARY FOR CORRECT ALIGNMENT OF ALL RIBS, PLACING HORIZONTAL REINFORCEMENT AND CONCRETE FLOW.

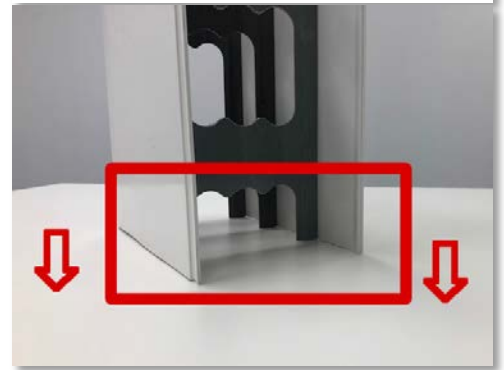

6

SETDOWNS AND PLACING HORIZONTAL REINFORCING BARS

All steps in footings and walls must be in suitable increments to align with the rib holes of adjacent panels to ensure correct lapping of reinforcing (as specified by the engineer) and the free flow of concrete.

Horizontal reinforcing is installed as the panels are erected and in strict accordance with the structural engineers' design.

Typically, 15 panels are erected and braced 6m lengths of reinforcement bars are placed at the centres specified. Another 20 panels are then erected and braced, and another 6m long bars are placed to provide lap as specified by the engineer.

In short run lengths of wall, the reinforcement needs to be cut to the appropriate length and, in the case of a blade wall, placed prior to the end of the wall being capped.



PARTICULAR CARE MUST BE TAKEN WHEN FEEDING HORIZONTAL REINFORCEMENT THROUGH INTERNAL RIBS SO THAT RIBS ARE NOT DAMAGED. DAMAGED RIBS INCREASE THE RISK OF BULGING AND BLOW-OUTS WHEN THE WALL IS POURED.

**SECTION THROUGH 110MM, 200MM, 250MM PERMAFORM WALL
(NEAR FACE PANEL NOT SHOWN FOR CLARITY)**

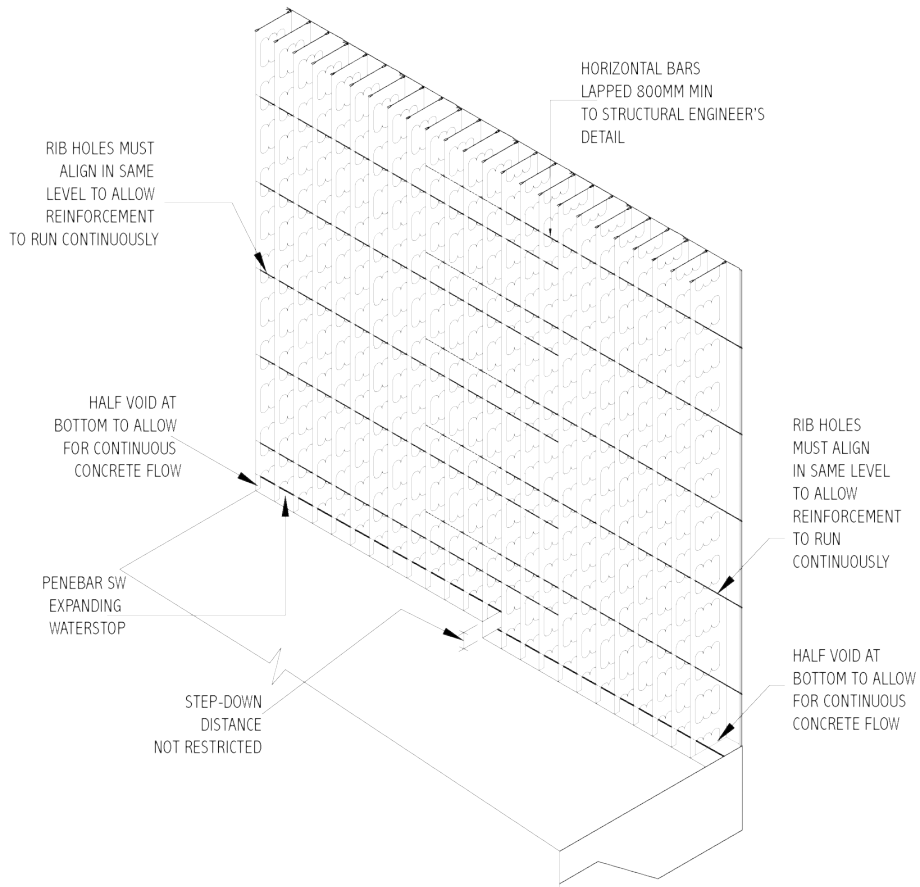

**SECTION THROUGH 155MM PERMAFORM WALL
(NEAR FACE PANEL NOT SHOWN FOR CLARITY)**

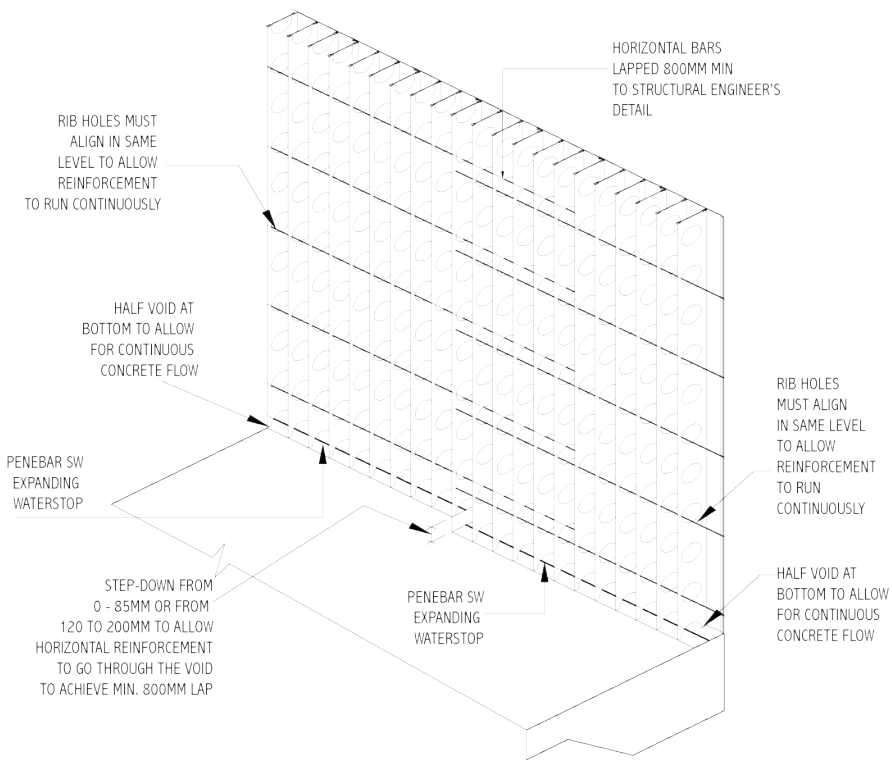

ENDING A WALL

As PERMAFORM panels come in 300mm wide sections, you may need to cut down a section in order to finish within the desired wall dimension. The PERMAFORM panel lock design offers the installer two options of ending a wall – either using an end cap (male or female) or a top cap installed vertically at the end of the wall with screws to its adjoining wall.

All end caps must be braced. Corners should be braced if not locked into an adjacent panel. Not doing so can result in bulging or blow-outs of end caps or unbraced corners.

OPTIONS FOR BRACING/PROPPING ENDS OF WALLS

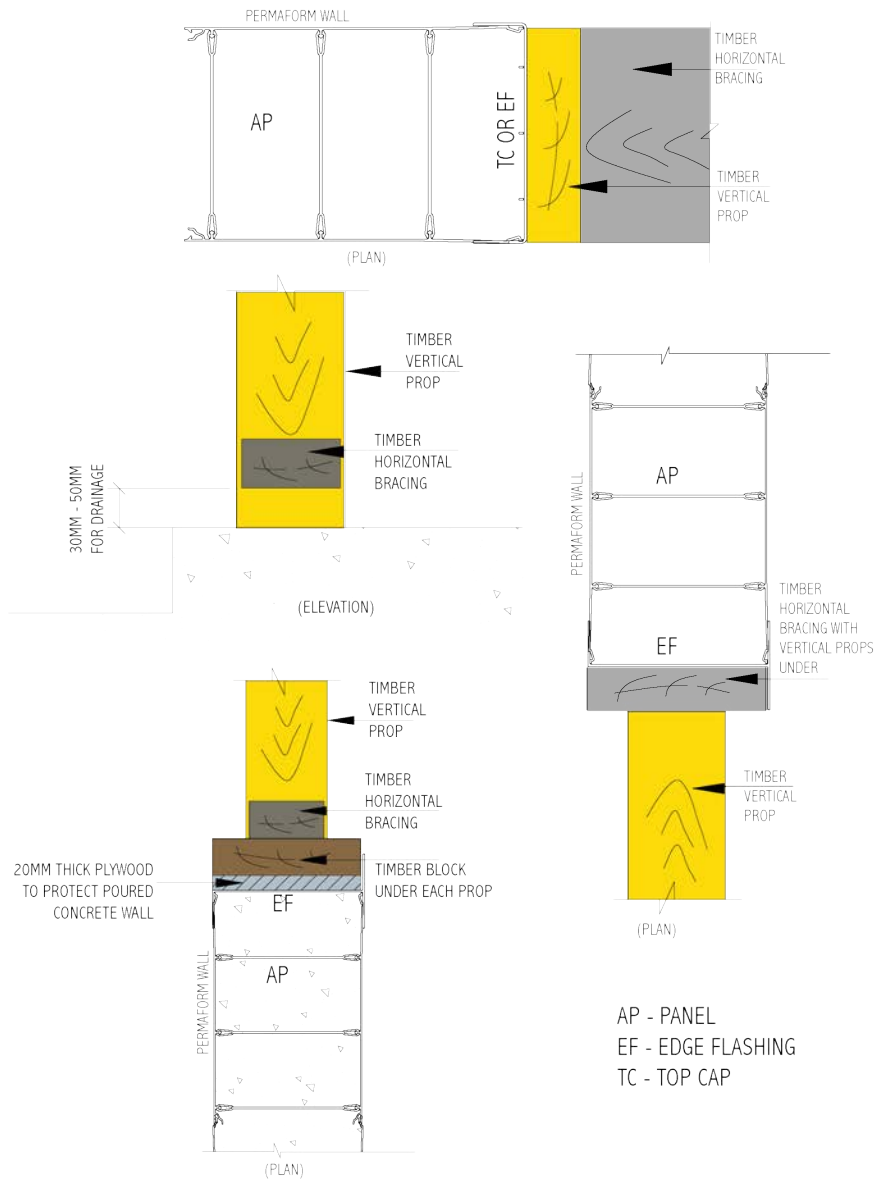

IRREGULAR CORNERS

FORMING ACUTE ANGLES

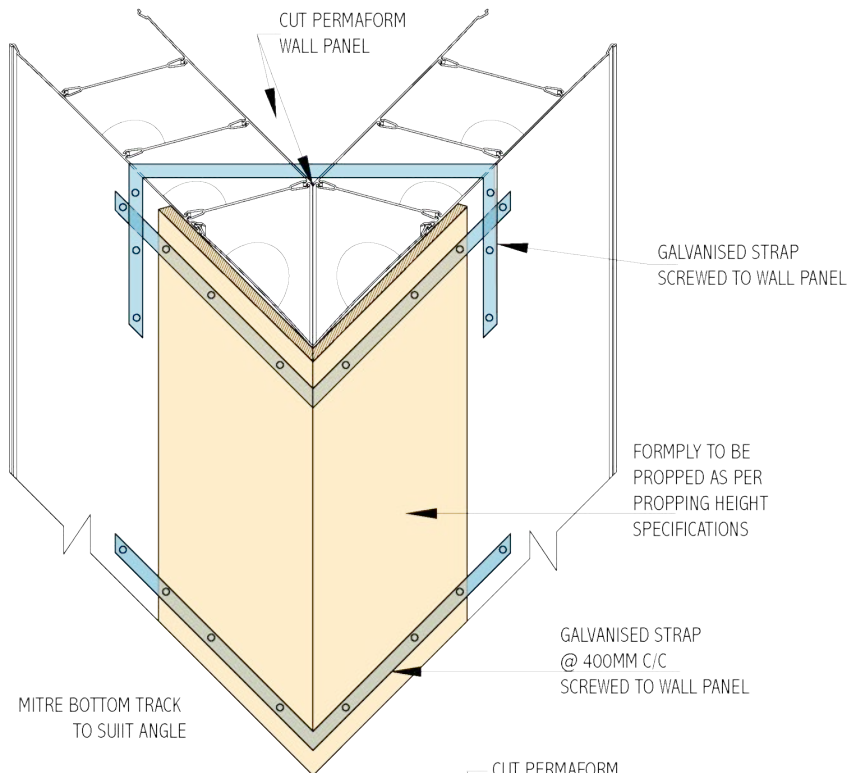

FORMING OBTUSE ANGLES

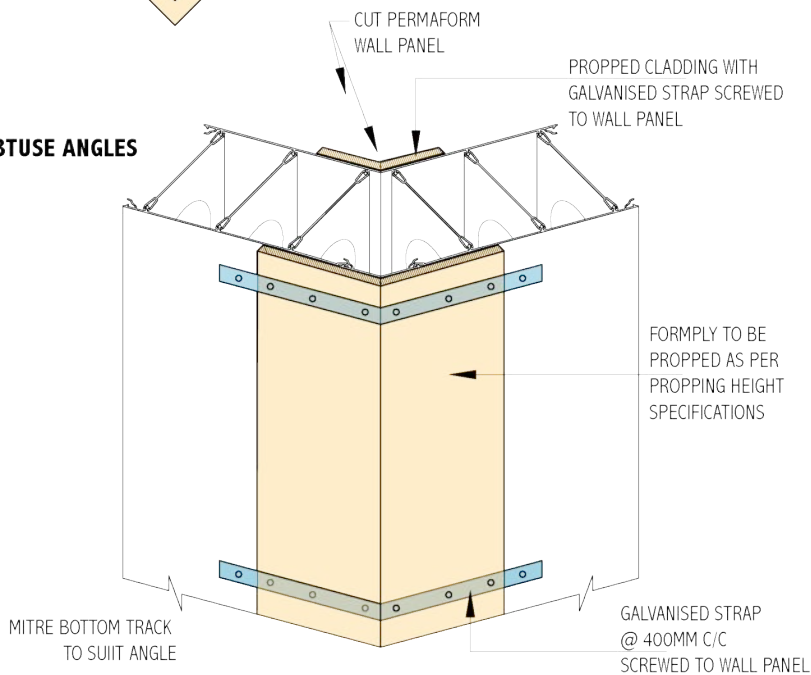

OPENINGS – WINDOWS, DOORS AND PENETRATIONS

OPENINGS IN PERMAFORM WALL

PROVIDE STRONGBACK AND DIAGONAL PROPS AT TOP OF OPENING WHEN NECESSARY

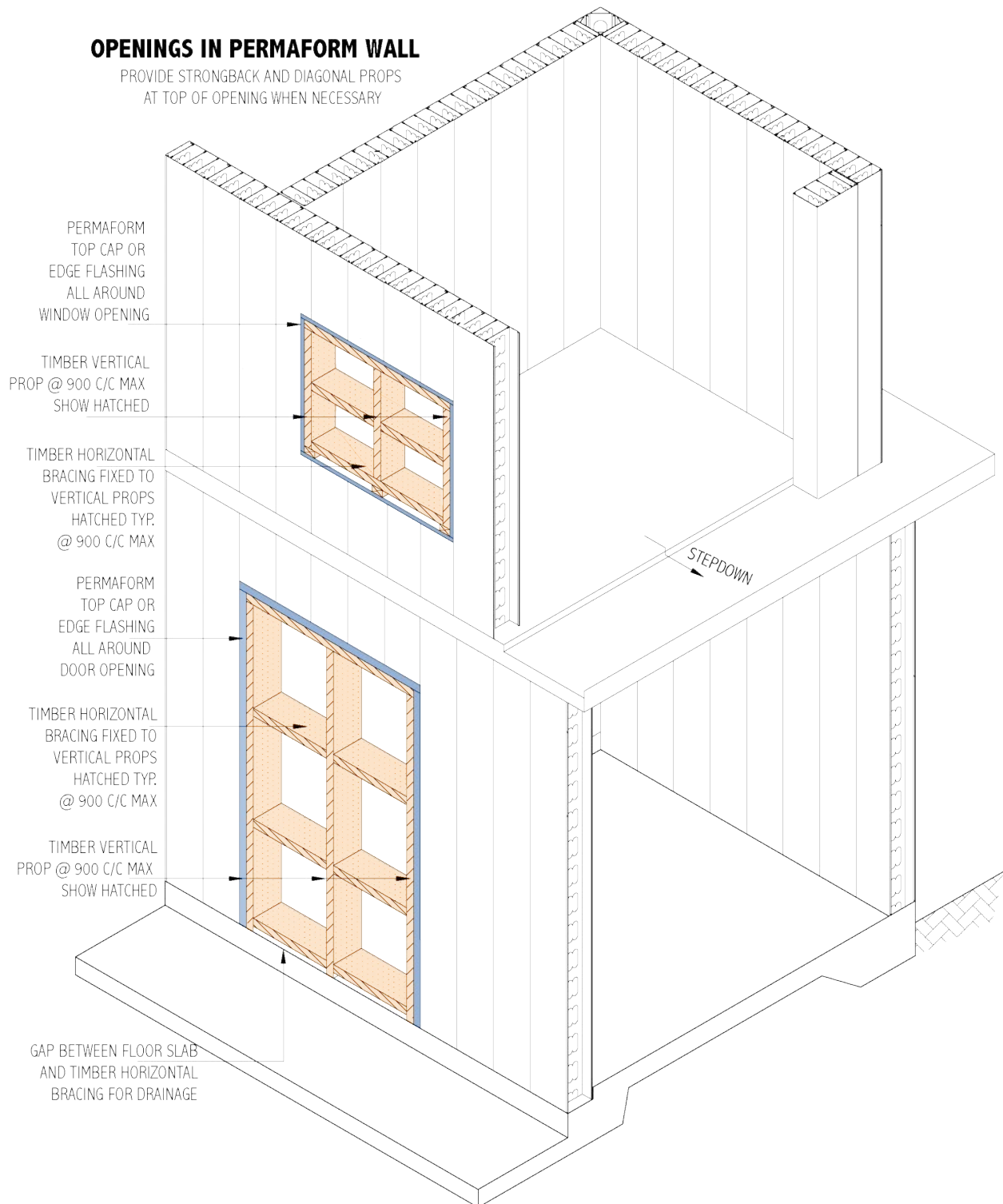

PERMAFORM
TOP CAP OR
EDGE FLASHING
ALL AROUND
WINDOW OPENING

TIMBER VERTICAL
PROP @ 900 C/C MAX
SHOW HATCHED

TIMBER HORIZONTAL
BRACING FIXED TO
VERTICAL PROPS
HATCHED TYP.
@ 900 C/C MAX

PERMAFORM
TOP CAP OR
EDGE FLASHING
ALL AROUND
DOOR OPENING

TIMBER HORIZONTAL
BRACING FIXED TO
VERTICAL PROPS
HATCHED TYP.
@ 900 C/C MAX

TIMBER VERTICAL
PROP @ 900 C/C MAX
SHOW HATCHED

GAP BETWEEN FLOOR SLAB
AND TIMBER HORIZONTAL
BRACING FOR DRAINAGE

STEPDOWN

Erect full length PERMAFORM panels sequentially until arriving to the first jamb. You may have to cut into the first jamb panel – this should be done prior to installation.

If a metal door frame is being fitted, the frame is slid into position with the throat of the frame over or into the last panel. The next full-sized panel is then placed in position having been engaged into the throat of the doorframe.

Alternatively, the panels either side of the door frame are fixed into position and plumbed (ensuring the opening between them is accurate). The frame can then be lowered into position, engaging into the

panels on both sides and dropping down into the head of the door frame.

Metal door frames require sufficient bracing to prevent distortion during pouring. This can be achieved by timber bracing.

For Fire doors, obtain certificates from the manufacturers for metal frames and doors for the required fire resistance level (FRL).

If metal frames (door, window penetrations) are built within the PERMAFORM panels and are to receive direct contact with wet concrete or moisture conditions, protect appropriately against corrosion (ig galvanising).

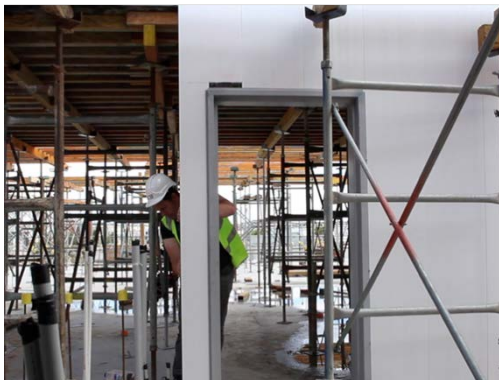

For windows, install sill panels, screw a top cap into place on the sill and the first jamb.

Install formwork timber framing to the internal measurements of the opening.

Place Top Cap on top of the timber framing for the head panels and the second jamb by screwing into the timber frame.

Install head panels.

Install full length PERMAFORM panel (the second jamb) and engage sill and header panels.

Screw the Top Cap into place by using screws on each face of the PERMAFORM panel at 200mm centres.

The vertical sides of the opening and the window head are capped using Top Caps cut to appropriate lengths and is fitted into the panels using adhesive and screws.

Large span lintels will need temporary propping during and after pour until adequately cured.

Refer to project structural engineer for advice

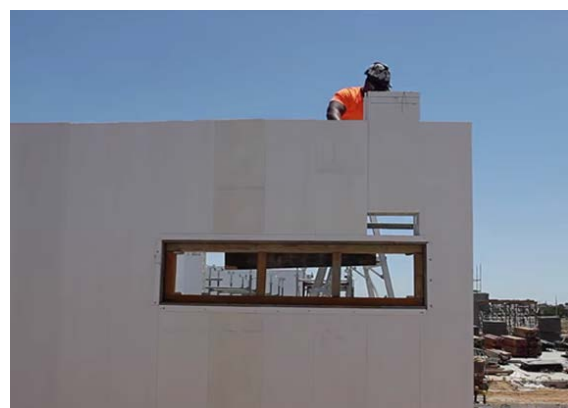

10 VERTICAL REINFORCING BARS

If a normal formwork deck is being erected, once the deck is in and it is safe to do so, the vertical reinforcing bars are lifted onto the deck. Slide the vertical bars from the top of the PERMAFORM panels at centres prescribed by the structural engineer.

Where the walls continue through to the next floor, the vertical bars are left longer by the amount required to clear the slab and act as the starter bar for the next floor.

Prior to placing each vertical bar, ensure it has a slight curve on the top end. This offset makes it easy when lowering the bar into the wall to guide it either side of the horizontal bars.

On projects where it is necessary to pour walls prior to the deck going in (for example, pre-cast slab systems) place the vertical reinforcement from either a mobile or temporary scaffold.

When the vertical bars are in place, tie the top of each vertical bar to a horizontal length of reinforcement (lacer bar) using normal reinforcement tie wire as specified. This holds the bars in the correct place during the concrete pour.

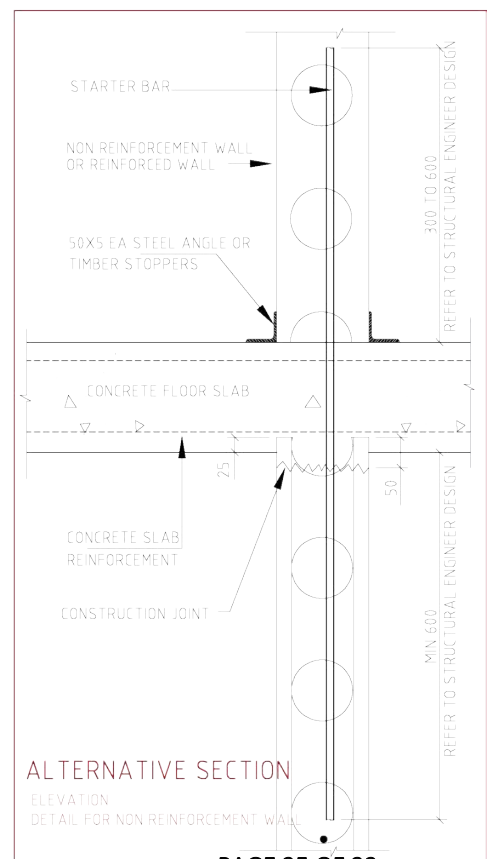
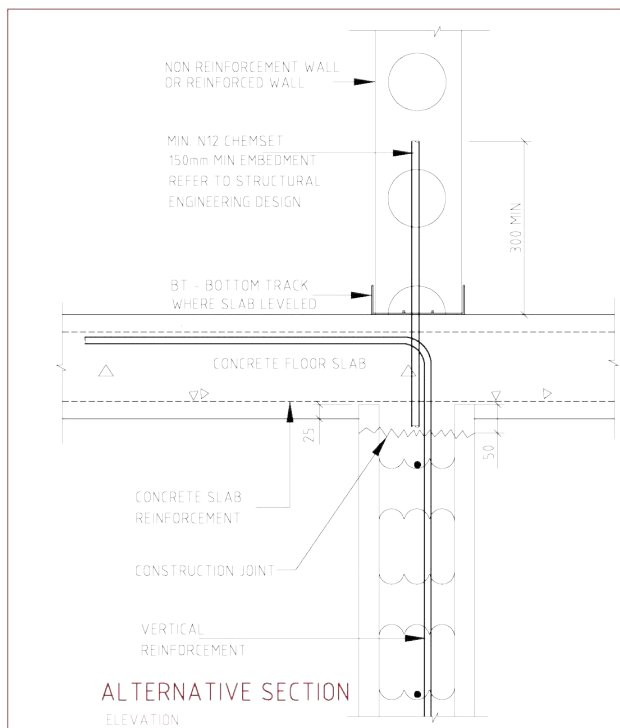
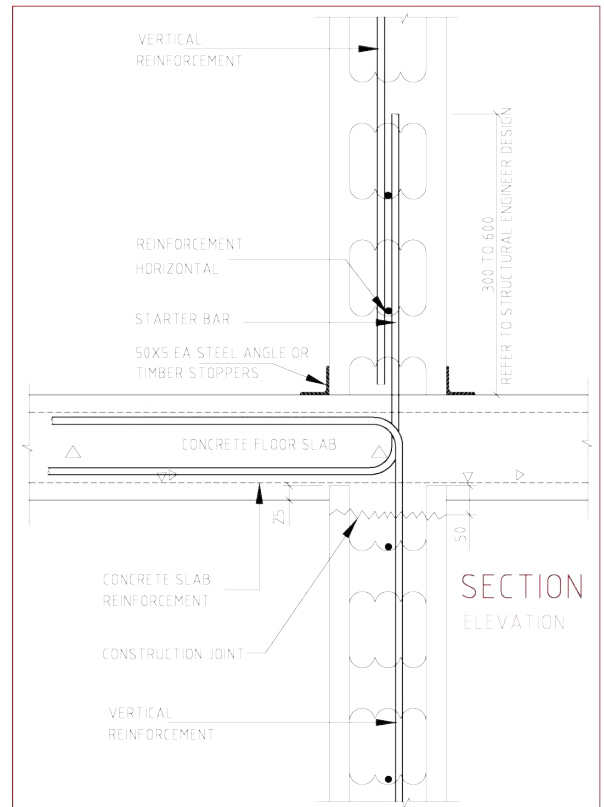

EXAMPLE OF REINFORCEMENT CONFIGURATION

ELEVATION

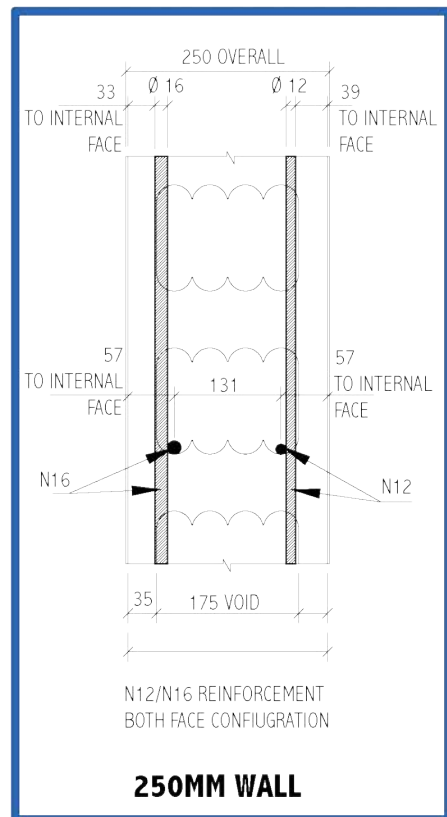
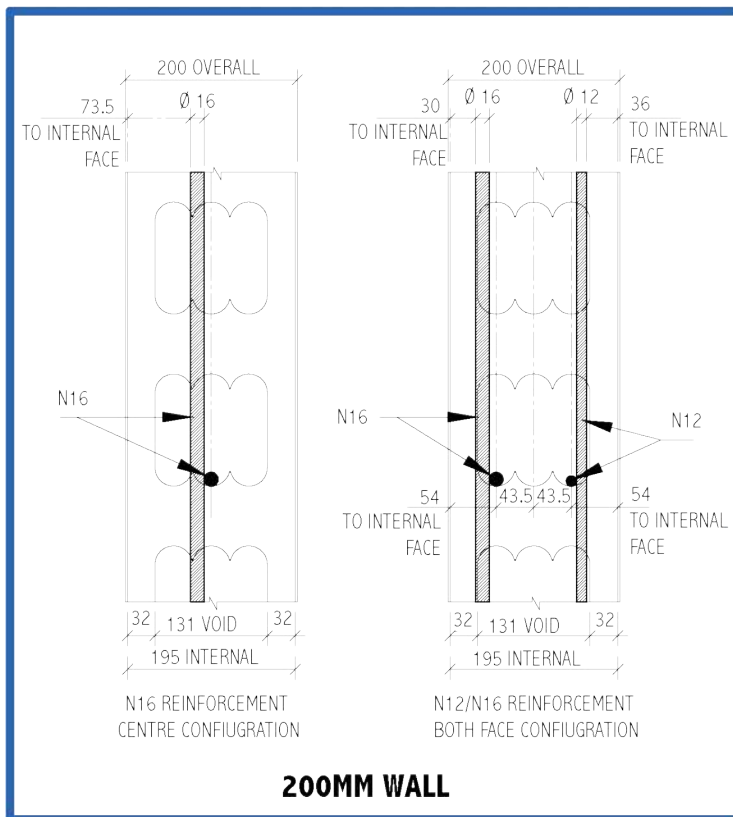
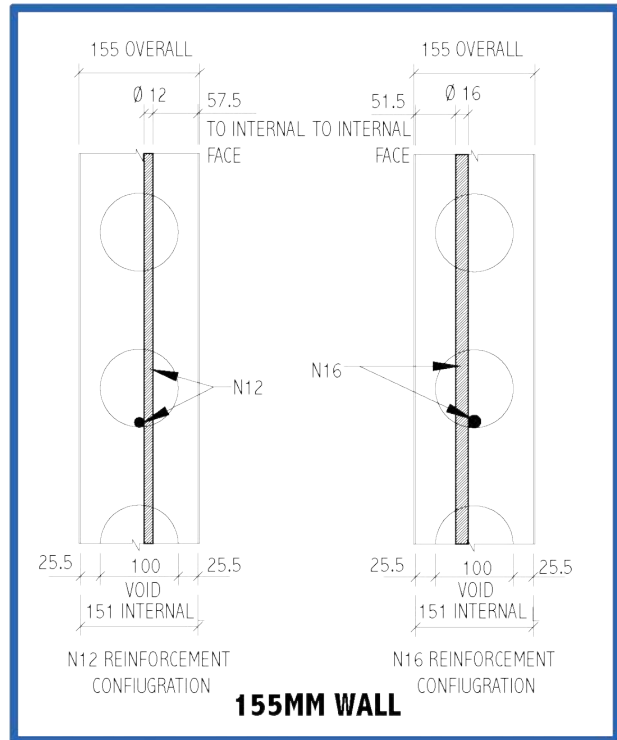
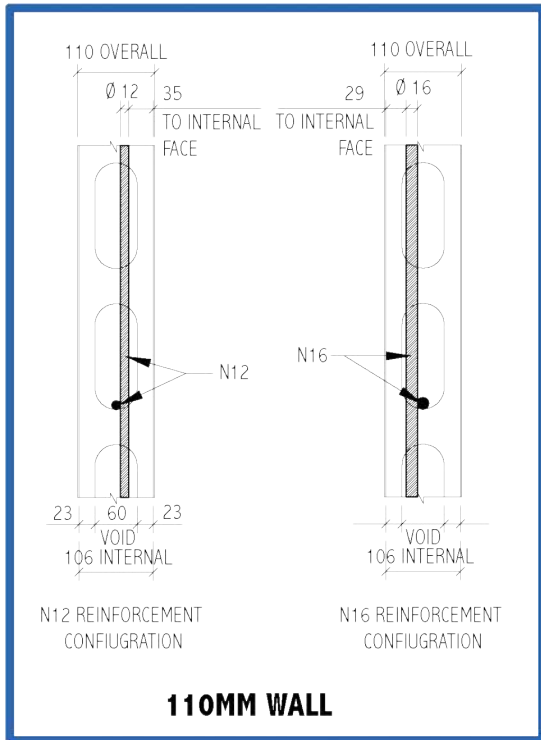

11A. PRE-POUR CHECKS

Prior to pouring the PERMAFORM wall, the installer, engineer and builder should perform a check of all walls ensuring they are straight, plumb square and true, and that reinforcing (both horizontal and vertical) has been placed as per the structural drawings and specifications.

Make sure all openings are the correct size. Ensure that all electrical and data conduits are in and according to the plan. Ensure all end caps and corners are correctly braced to prevent any bulging or blow-outs.

Perform the following checks:

- Concrete footing flat and free of debris
- Bottom track installed correctly
- Water proofing/hydrophilic sealant installed correctly
- All walls installed in correct locations as per drawings and survey
- All penetrations locations provided and installed in accordance with site mark-out
- All walls have been installed straight and plumb
- No ribs/diaphragms are damaged, split or cracked
- All wall panels have been clipped in correctly with no visible gaps
- All finish wall heights have been installed as per drawings and specifications
- All corners and stop ends are adequately braced
- All window/door openings have been formed and braced correctly
- All walls checked for areas of minor damage and patched appropriately
- For walls above 4m: midway horizontal strongback to be screwed to panels and propped
- Props installed at a maximum spacing of 1.8m

A complete pre-pour checklist can be found in the appendices.

11B. TEMPORARY PATCHING

When installation of panels is complete, and before the pour, all walls need to be checked for areas of minor damage. They must be temporarily patched to ensure they don't become weak points and blow-out during the concrete pour.

Complete any patching using appropriate sized pieces of form-ply tek-screwed over the area. After the pour, these patches are simply removed by reversing out the tek-screws.

11C. RECOMMENDED CONCRETE QUANTITY

Net concrete quantity

Excluding wastage for pump/hose hopper

Concrete must be placed using a suitable boom pump via a delivery hose.

	110mm	155mm	200mm
Per cubic metre of concrete	9.5m ² of wall area	6.67m ² of wall area	5.5m ² of wall area
Per square metre of wall area	0.105m ³ of concrete	0.15m ³ of concrete	0.182m ³ of concrete

11D. SUGGESTED CONCRETE MIX

The concrete supplier is responsible for providing a mix design that is suitable for filling PERMAFORM.

The mix must be designed with enhanced flow characteristics and should be minimum 150 slump.

The following is a guide only:

Cement type	Type GP in accordance to AS3972. Fly ash in accordance with AS3582.1 may be used as cement replacement.
Characteristic 28 days compressive strength	20MPa to 60MPa as specified by design engineer
Concrete pump nozzle size	Internal diameter of 75mm-100mm provided the concrete flow pressure is controlled.

12

POUR SEQUENCE

Below sets out the recommended number of concrete passes required. Higher MPa mixes will gel faster than low strength mix designs. These guidelines will vary according to site conditions, extra passes and extra gelling time may be required in wet or cold weather. In cases of extreme weather, the concrete pour should be postponed.

- Flowing slump concrete: 150mm to 180mm slump.
- Concrete can be mechanically vibrated during placing by using concrete vibrator 20mm to 25mm diameter head to the depth of 500mm within the final layer to assist flow under low pressure.
- After first pour layer, check wall straightness, integrity of ribs. (ribs can be easily damaged from in-situ starter bars)
- Pouring wall same day with the suspended slab: Pour wall concrete first and allow it to set prior to pouring of the slab.

Wall Ht(m)	110MM WALL			155MM WALL			
	1 st pour	2 nd pour	3 rd pour	1st pour	2nd pour	3rd pour	4th pour
2.8	1.2	1.6		1.2	1.6		
3.0	1.2	1.8		1.2	1.8		
3.3	1.2	2.1		1.2	2.1		
3.6	1.2	1.2	1.2	1.2	1.2	1.2	
4.0	1.2	1.2	1.6	1.2	1.2	1.6	
5.0				1.2	1.8	2.0	
5.6				1.2	1.2	1.4	1.8
6.0				1.2	1.2	1.6	2.0
6.6				1.2	1.4	1.8	2.2

Wall Ht(m)	200MM WALL				250MM WALL			
	1st pour	2nd pour	3rd pour	4th pour	1st pour	2nd pour	3rd pour	4th pour
2.8	1.2	1.6			1.2	1.6		
3.0	1.2	1.8			1.2	1.8		
3.3	1.2	2.1			1.2	2.1		
3.6	1.2	1.2	1.2		1.2	1.2	1.2	
4.0	1.2	1.2	1.6		1.2	1.2	1.6	
5.0	1.2	1.8	2.0		1.2	1.8	2.0	
5.6	1.2	1.2	1.4	1.8	1.2	1.2	1.4	1.8
6.0	1.2	1.2	1.6	2.0	1.2	1.2	1.6	2.0
6.6	1.2	1.4	1.8	2.2	1.2	1.4	1.8	2.2

USE FLOWING SLUMP CONCRETE. ALLOW A MINIMUM OF **45 MINUTES** BETWEEN POURS. FOR WALLS GREATER THAN 6.6M AND UP TO 8.0M THE FIRST 3 LAYERS FROM THE 6.6M SCHEDULE TO BE ADOPTED

13 POUR PROCEDURE

When pouring, do not aim the pump directly at corners or wall ends. Always point the pump nozzle towards a rib/diaphragm. The pump nozzle should remain at least 500mm away from wall/column ends.

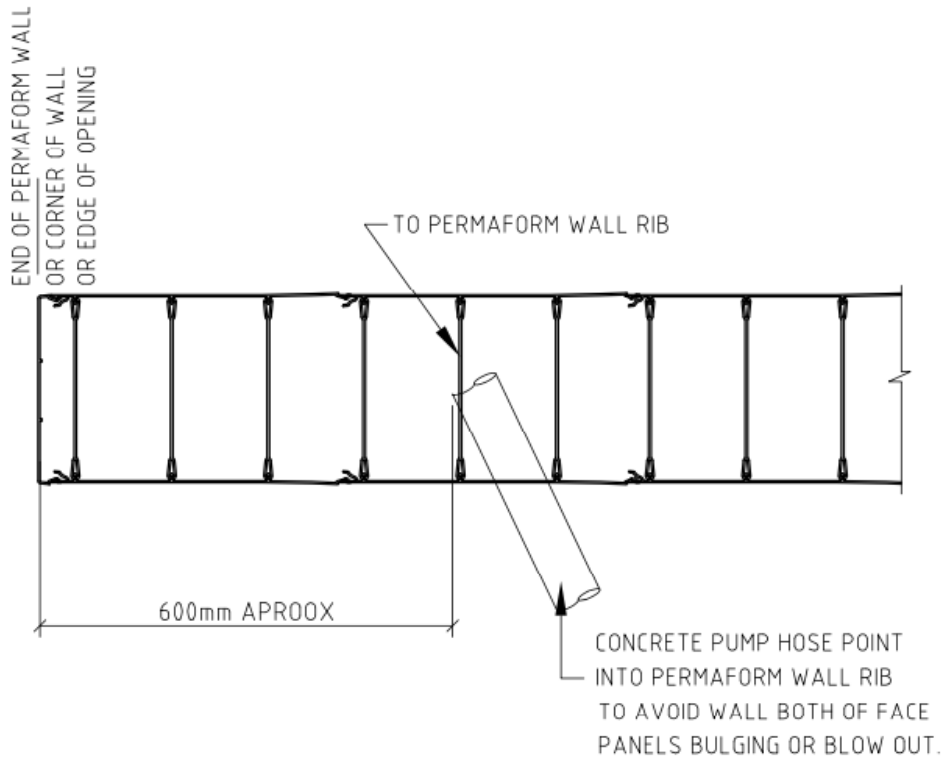

CONCRETE PUMP HOSE LOCATION PLAN AT END OF WALL / CORNER OF WALL / EDGE OPENING

When moving around the walls filling them, remember that the shorter or thinner a section of wall is, the faster it will fill.

Do not leave finished concrete surface uneven at the top of forms. Following compaction at the top of the walls, screed the concrete to achieve a smooth and even surface.

When slab and walls are poured at the same time, finish the concreting for the walls first. This should provide enough time for wall concrete to settle before the slab concreting takes place over the particular wall.

While pouring, be sure to visually inspect walls regularly to ensure vertical alignment and plumb of the panels is maintained. Stop the pour, or proceed at reduced speed if any areas start to move. Keep props, timbers or plywood readily available to provide temporary bracing if required.

14 VIBRATING

Proper compacting of concrete is essential to prevent voids in the finished walls.

Pay particular attention to the sides of all openings, bulkheads and any areas that have a high concentration of steel.

Use a 25mm pocket vibrator. Vibrating helps ensure the concrete mix slurry fills all voids, particularly at joints. When vibrating, take care not to damage ribs or the external face of the panels. Place the vibrator in the upper 300mm of the wall panel.

PERMAFORM is made from PVC and is non-porous. This means it does not absorb water like masonry, fibre-cement or plywood. This increases the flowability of concrete and reduces honeycombing.

15 POST-POUR

15A. CLEAN UP

Any household detergent can be used for general cleaning purposes.

Any concrete slurry that has spilt onto the PERMAFORM panels can be easily removed if it is washed with high pressure water within 30 minutes before the slurry hardens.

If concrete slurry has hardened, removing it may damage the walls' surface. If this occurs, make sure the slurry is at least two weeks old before attempting to remove it. Apply hydrochloric-acid diluted 1/10 or less onto the slurry with a brush and clean with a soft brush.

Apply high water pressure to remove the solution and slurry within 10 minutes.

15B. PATCHING

If surface damage has occurred, it can be patched with a two-part polyester resin (for example Bostik Bog).

The damaged part of the surface can be cut and removed.

If repairing damaged concrete, complete concrete patching by conventional means. Fill the surface of the patched concrete with resin of not less than 2mm in thickness to match the adjacent panel surface.

Sand and level the dried resin surface and apply etching primer to the damaged area only.

15C. REMOVING PROPS AND BRACING

Braces and props should be removed once the slab over is poured or the roof is attached.

If it's necessary to remove braces earlier, approval must be obtained from the project engineer, especially when the wall is being used as a retaining wall and will be back-filled against.

Removing braces should always be done in accordance with the engineer's specifications.

15D. CHECK FOR VOIDS

After the PERMAFORM panels have been core filled, they should each be checked by tapping gently with hammer on both sides to check compaction (with caution not to damage the surface). Should a hollow in the wall be identified, the location should be marked. A high strength grout should then be injected into the panel to fill the hollow.

This process should be done in conjunction with specification from the grout supplier and the methodology approved by the project engineer.

15E. VOID RECTIFICATION PROCESS

IDENTIFICATION

Tap panels in a 100mm x 100mm grid with the end of a hammer stick, screwdriver or chisel. If "hollow" or "drummy" noise is heard mark the area. If necessary, confirm by driving a 50mm nail or drilling a 5mm drill bit into the top of the marked panel area (the hole will be removed by a larger hole if a void is present). If nail or drill bit penetrates more than 10mm then a void is present.

RECTIFICATION PROCESS

1. Drill a 40mm hole into the panel at the very top of the void area (if possible the hole should extend just above void). Align and attach a 40mm PVC pipe fitting 450 or 900 to the wall and secure accordingly so as to stay in place through the filling process.
2. Fill void with non-shrinking grout of an equivalent or higher strength material than was used to fill the walls, i.e. if walls have been filled with 32 MPA concrete typically 40 MPA non-shrinking grout is used.
3. Fill the void by pouring in liquid non-shrinking grout mixed to manufacturers specification into attached pipe fitting (this can be done via a funnel or similar), tap void with rubber mallet to aid in movement, continue to fill until the top of pipe fitting is full.
4. Allow non-shrinking grout to harden.
5. Next day the fitting can be removed with a hammer or grinder

CONFIRMATION

Confirmation that the void has been filled is typically done by repeating the tapping process or ground penetrating radar or "x-ray" concrete scanning can be used to ensure no voids are left present in the walls.

TECH SPECS DATASHEET

AS AT AUGUST 2019



PRODUCT SPECIFICATIONS

PROFILES	110MM, 150MM, 200MM AND 150MM	PANEL WIDTH	300 MM
PVC THICKNESS	2.6 MM	PVC DENSITY	1,300 KG/ M ³
LIFE EXPECTANCY	MINIMUM 50 YEARS	FINISH	GLOSS WHITE, WATER RESISTANT
HEIGHT	ALL PANELS CAN BE ORDERED TO CUSTOM HEIGHTS MINIMUM 1.0M – MAXIMUM 8.0M STOCK HEIGHTS: 2.8M, 3M, 3.3M, 3.6M, 3.8M, 4.0M, 4.6M, 5M, 6M.	UV STABILITY	NOT AFFECTED BY EXPOSURE TO SUNLIGHT EITHER IN STORAGE OR AS FINISHED PRODUCT
		SPECIFIC PPE	NONE REQUIRED. GLOVES ARE NOT ESSENTIAL, BUT ON SITES WHERE MANDATORY, GLOVES WITH RUBBER FINGERS AND PALM INFILL WILL REMOVE RISK OF SLIPPING.
		MSDS	READILY AVAILABLE
		ORDERING LEAD TIME	STOCK HEIGHTS DELIVERED TO MAJOR CAPITAL CITIES WITHIN SEVEN DAYS FROM ORDER. CUSTOM HEIGHT PANELS WITHIN FIVE WEEKS.
		SHIPPING AND FREIGHT	WE OFFER DELIVERY AT COST, OR YOU CAN ARRANGE YOUR OWN
		PAYMENT TERMS	COD OR 30-DAY ACCOUNT UPON APPLICATION

	CONCRETE VOLUME (M ³ /M ²)	PRODUCT WEIGHT (KG/ M ²)	FIRE RATING (MINUTES MINIMUM)
110MM PROFILE	0.101	14.7	90
155MM PROFILE	0.146	15.8	180
200MM PROFILE	0.188	16.8	≥ 240
250MM PROFILE	0.2404	17.8	≥ 240

CERTIFICATIONS AND COMPLIANCE

CODE, SPECIFICATION OR STANDARD	CERTIFIED BY
AS1530.3 - IGNITABILITY, FLAME PROPAGATION, HEAT RELEASE AND SMOKE RELEASE	CSIRO
AS/NZ3837:1998 - HEAT & SMOKE RELEASE RATES	CSIRO
BCA PARTS A2 & C1 - HEAT & SMOKE RELEASE REQUIREMENTS	CSIRO; SGS-CSTC; MURTAGH BOND STRUCTURAL ENGINEERS
BCA PART F5 – ACOUSTIC PERFORMANCE, SOUND TRANSMISSION AND INSULATION	RUDDS CONSULTING ENGINEERS
GREEN BUILDING COUNCIL OF AUSTRALIA – GREEN STAR OFFICE DESIGN	CETEC

ABBREVIATIONS AND ACRONYMS

- + BCA – Building Code of Australia
- + PPE – Personal Protective Equipment
- + MSDS – Material Safety Data Sheet
- + CSIRO – Commonwealth Scientific and Industrial Research Organisation
- + SGS-CSTC - the world's leading inspection, verification, testing and certification company. www.sgs.com
- + CETEC Pty Ltd - a professional and independent consultancy delivering scientific and technical based solutions.
- + CETEC focuses on providing Environmental, Sustainability and OH&S services and solutions for buildings and the built environment www.cetec.com.au

PERMAFORM APPLICATION SAFETY DATA SHEET



PERMAFORM IS A PERMANENT PVC CONCRETE WALL FORMWORK SYSTEM DESIGNED AND PRODUCED FOR AUSTRALIAN CONDITIONS

PERMAFORM is a permanent PVC wall formwork system for concrete retention which remains in place for the life of the structure, designed and produced for Australian conditions. As such it does not affect the structural integrity of the concrete element.

1- PRODUCT IDENTIFIER AND CHEMICAL IDENTITY

PRODUCT NAME: PERMAFORM

Recommended Use of the Chemical and Restriction on Use: Formwork system - extruded rigid polymer material used for permanent formwork for retaining concrete when pouring and subsequently as permanent wall cladding.

DETAILS OF MANUFACTURER/ IMPORTER:

Permaform International Pty Ltd
PO Box 490
Fyshwick ACT 2609

PH: 1800 737 623
Emergency: 0488 040 603

2- HAZARDS IDENTIFICATION

PRECAUTIONARY STATEMENTS

- + P272 Contaminated work clothing should not be allowed out of the workplace.
- + P201 Obtain special instructions before use.
- + P202 Do not handle until all safety precautions have been read and understood.
- + P321 Specific treatment (see on this label).
- + P308+P313 If exposed or concerned: Get medical advice/attention.
- + P333+P313 If skin irritation or rash occurs: Get medical advice/attention.
- + P302+P352 If on skin Wash with plenty of soap and water.
- + P362+P364 Take off contaminated clothing and wash it before reuse.
- + P405 Store locked up.
- + P501 Dispose of contents/container in accordance with local/regional/national regulations.

3- COMPOSITION AND INFORMATION ON INGREDIENTS

CHEMICAL CHARACTERIZATION: MIXTURES

Description: Mixture of substances listed below with nonhazardous additions.

ACCORDING TO SAFE WORK AUSTRALIA

Printing date 11.04.2013; Revision: 11.04.2013;
Product Name: PERMAFORM 36.0.9

HAZARDOUS COMPONENTS:

471-34-1 calcium carbonate 4%; 12202-17-4 Lead oxide sulphate; Repr. 1B, H360; STOT RE 2, H373; Aquatic Acute 1, H400; Aquatic Chronic 1, H410; Acute Tox. 4, H302; Acute Tox. 4, H332 1% 8013-07-8 Soybean oil, epoxidized Skin Sens. 1, H317 1%

PERMAFORM INTERNATIONAL PTY LTD
ABN 70 609 958 527

PO BOX 490
Fyshick ACT 2609

PH **1800 PERMAFORM**
(1800 737 623)

permaform.com.au
info@permaform.com.au

PERMAFORM APPLICATION SAFETY DATA SHEET



4- FIRST AID MEASURES

INHALATION: If inhaled, remove to fresh air. Seek medical attention if breathing problems develop.

SKIN CONTACT: In case of skin contact, immediately remove contaminated clothing and wash affected areas with water and soap. Seek medical attention if symptoms occur.

EYE CONTACT: In case of eye contact, rinse cautiously with water for several minutes. Remove contact lenses, if present and easy to do. Continue rinsing. Seek medical attention.

INGESTION: If swallowed, do not induce vomiting. Do not give anything by mouth to an unconscious person. Seek immediate medical attention.

5- FIRE FIGHTING MEASURES

SUITABLE EXTINGUISHING MEDIA

Use fire-extinguishing methods suitable to surrounding conditions.

SPECIFIC HAZARDS ARISING FROM THE CHEMICAL

No further relevant information available.

SPECIAL PROTECTIVE EQUIPMENT AND PRECAUTIONS FOR FIRE FIGHTERS

Wear Safe Work Australia approved self-contained breathing apparatus and full protective clothing.

6- ACCIDENTAL RELEASE MEASURES

PERSONAL PRECAUTIONS, PROTECTIVE EQUIPMENT AND EMERGENCY

PROCEDURES: Wear Safe Work Australia full protective clothing. Evacuate all non-essential personnel from affected area. Do not breathe vapours/dusts. Ensure adequate ventilation.

ENVIRONMENTAL PRECAUTIONS: In the event of a major spill, prevent spillage from entering drains or watercourses.

METHODS AND MATERIALS FOR CONTAINMENT AND CLEANING UP:

Collect the pieces and place into a suitable container for disposal. Avoid generating dusts. Provide adequate ventilation.

PERMAFORM APPLICATION SAFETY DATA SHEET



7- HANDLING AND STORAGE

PRECAUTIONS FOR SAFE HANDLING: Use of safe work practices are recommended to avoid eye or skin contact and inhalation of dusts. Use only outdoors or in a well-ventilated area.

Food, beverages and tobacco products should not be stored or consumed where this material is in use. Always wash hands before smoking, eating, drinking or using the toilet. Wash contaminated clothing and other protective equipment before storage or re-use.

Provide eyewash fountains and safety showers in close proximity to points of potential exposure.

CONDITIONS FOR SAFE STORAGE: Store in a cool, dry and well-ventilated area. Avoid accumulation of dust.

8- EXPOSURE CONTROLS AND PERSONAL PROTECTION

EXPOSURE STANDARDS (SAFE WORK AUSTRALIA): 471-34-1 calcium carbonate NES 10 mg/m³

ENGINEERING CONTROLS: Provide exhaust ventilation or other engineering controls to keep the airborne concentrations of vapour below occupational exposure standards.

PERSONAL PROTECTIVE EQUIPMENT (PPE): Wear Safe Work Australia full protective clothing.

RESPIRATORY PROTECTION: Use dust mask when cutting product. See Australian Standards AS/NZS 1715 and 1716 for more information.

SKIN PROTECTION: Impermeable gloves and protective clothing. See Australian Standards AS/NZS 2161, 2210.1 and 2210.2 for more information.

EYE AND FACE PROTECTION: Safety glasses with top and side shields or goggles. See Australian Standards AS/NZS 1336 and 1337 for more information.

9- PHYSICAL AND CHEMICAL PROPERTIES

APPEARANCE: Form: Solid - hollow-type rib reinforced plastic material comprising of two PVC panel facings adhered onto a concrete block with three internal reinforcing PVC ribs.

Colour: Off white

Odour: None

MELTING POINT/MELTING RANGE: No information available

FLAMMABILITY: Non-flammable

RELATIVE DENSITY AT 20 °C: 1300 kg/m³

PERMAFORM APPLICATION SAFETY DATA SHEET



10- STABILITY AND REACTIVITY

POSSIBILITY OF HAZARDOUS REACTIONS:

Hazardous polymerisation will not occur.

CHEMICAL STABILITY: Stable at ambient temperature and under normal conditions of use.

CONDITIONS TO AVOID: No further relevant information available.

INCOMPATIBLE MATERIALS: No further relevant information available.

HAZARDOUS DECOMPOSITION PRODUCTS: No dangerous decomposition products known.

11- TOXICOLOGICAL INFORMATION

TOXICITY: LD50/LC50 VALUES RELEVANT FOR CLASSIFICATION

471-34-1 calcium carbonate

Oral LD50 6450 mg/kg (rat)

8013-07-8 Soybean oil, epoxidized Oral LD50

21000-40000 mg/kg (rat)

Dermal LD50 >2000 mg/kg (rabbit)

ACCORDING TO SAFE WORK AUSTRALIA

Printing date 11.04.2013 Revision: 11.04.2013

ACUTE HEALTH EFFECTS: Skin Corrosion / Irritation: No information available

SERIOUS EYE DAMAGE / IRRITATION: No information available

RESPIRATORY OR SKIN SENSITISATION: Sensitization possible through skin contact.

GERM CELL MUTAGENICITY: No information available

CARCINOGENICITY: Polyvinyl chloride is classified by IARC as a Group 3 - Not classifiable as to its carcinogenicity to humans.

SPECIFIC TARGET ORGAN TOXICITY (STOT) - SINGLE EXPOSURE: No information available

SPECIFIC TARGET ORGAN TOXICITY (STOT) - REPEATED EXPOSURE: No information available

CHRONIC HEALTH EFFECTS: No information available

EXISTING CONDITIONS AGGRAVATED BY EXPOSURE: No information available

12- ECOLOGICAL INFORMATION

ECOTOXICITY AQUATIC TOXICITY

8013-07-8 Soybean oil, epoxidized EC50 / 24 hours > 100 mg/l (daphnia)

Inhalation LC50 900 mg/m³ (flathead minnows)

PERSISTENCE AND DEGRADABILITY

No further relevant information available.

BIOACCUMULATIVE: Potential: No further relevant information available.

MOBILITY IN SOIL: No further relevant information available.

PERMAFORM APPLICATION SAFETY DATA SHEET



13- DISPOSAL CONSIDERATIONS

DISPOSAL METHODS AND CONTAINERS:
Dispose according to applicable local and state government regulations.

SPECIAL PRECAUTIONS FOR LANDFILL OR INCINERATION: Please consult your state Land Waste Management Authority for more information.

UN NUMBER: ADG, IMDG, IATA: Not applicable

PROPER SHIPPING NAME: ADG, IMDG, IATA: Not applicable

DANGEROUS GOODS CLASS: ADG CLASS: Not applicable

PACKING GROUP: ADG, IMDG, IATA Not applicable

14- TRANSPORT INFORMATION

UN NUMBER: ADG, IMDG, IATA Not applicable

PROPER SHIPPING NAME: ADG, IMDG, IATA Not applicable

DANGEROUS GOODS CLASS: ADG Class: Not applicable

PACKING GROUP: ADG, IMDG, IATA Not applicable

15- REGULATORY INFORMATION

AUSTRALIAN INVENTORY OF CHEMICAL SUBSTANCES: All ingredients are listed.

16- OTHER INFORMATION

CREATION DATE: 11 April 2013

PREPARED BY: MSDS.COM.AU Pty Ltd
www.msds.com.au

DISCLAIMER: This MSDS is prepared in accord with the Safe Work Australia document "Code of Practice for the Preparation of Safety Data Sheets for Hazardous Chemicals - December 2011"

The information contained in this material safety data sheet is provided in good faith and is believed to be accurate at the date of issuance. Permaform Australia Pty Ltd makes no representation of the accuracy or comprehensiveness of the information and to the full extent allowed by law excludes all liability for any loss or damage related to the

supply or use of the information in this material safety data sheet. MSDS.COM.AU Pty Ltd is not in a position to warrant the accuracy of the data herein. The user is cautioned to make their own determinations as to the suitability of the information provided to the particular circumstances in which the product is used.



1800 PERMAFORM

ABN 70 609 958 527

WWW.PERMAFORM.COM.AU

ORDERS@PERMAFORM.COM.AU

PERMAFORM INTERNATIONAL Pty Ltd

TERMS & CONDITIONS OF TRADE

1. Definitions

- 1.1 "Permaform" means Permaform International P/L ABN: 70 609 958 527.
- 1.2 "Customer" means the person/s buying the Goods as specified in any invoice, document or order, and if there is more than one Customer is a reference to each Customer jointly and severally.
- 1.3 "Agreement" refers to any agreement between Permaform and the customer whereby Permaform supplies the goods and services to the customer.
- 1.4 "Goods" means all Goods or Services supplied by Permaform to the Customer at the Customer's request from time to time (where the context so permits the terms 'Goods' or 'Services' shall be interchangeable for the other).
- 1.5 "Price" means the Price payable for the Goods as agreed between Permaform and the Customer in accordance with clause 5 below.
- 1.6 "GST" means Goods and Services Tax as defined within the "A New Tax System (Goods and Services Tax) Act 1999" (Cth).
- 1.7 "Default" means an invoice not paid by the due date on the Permaform invoice to the Customer.
- 1.8 "Deposit Payment" refers to the payments following the orders to confirm Permaform's product supply in cleared funds for each order or project or customer.

2. Acceptance

- 2.1 The Customer is taken to have exclusively accepted and is immediately bound, jointly and severally, by these terms and conditions if the Customer places an order for or accepts delivery of the Goods.
- 2.2 These terms and conditions may only be amended with the consent of both parties in writing and shall prevail to the extent of any inconsistency with any other document or agreement between the Customer and Permaform.

3. Electronic Transactions Act 2001

- 3.1 Electronic signatures shall be deemed to be accepted by either party providing that the parties have complied with Section 9 of the Electronic Transactions Act 2001 or any other applicable provisions of that Act or any Regulations referred to in that Act.

4. Change in Control

- 4.1 The Customer shall give Permaform not less than fourteen (14) days prior written notice of any proposed change of ownership of the Customer and/or any other change in the Customer's details (including but not limited to, changes in the Customer's name, address, contact phone or fax number/s, or business practice). The Customer shall be liable for any loss incurred by Permaform as a result of the Customer's failure to comply with this clause.

5. Price and Payment

- 5.1 At Permaform's sole discretion the Price shall be either:
 - (a) as indicated on any invoice provided by Permaform to the Customer; or
 - (b) the Price as at the date of delivery of the Goods according to Permaform's current price list; or
 - (c) Permaform's quoted price (subject to clause 5.2) which will be valid for the period stated in the quotation or otherwise for a period of thirty (30) days.
- 5.2 Permaform reserves the right to change the Price if a variation to Permaform's quotation is requested. Any variation from the plan of scheduled Services or specifications (including, but not limited to, any variation as a result of additional works required due to unforeseen circumstances such as a result of any increase to Permaform in the cost of materials and labour) will be charged for on the basis of Permaform's quotation and will be shown as variations on the invoice.
- 5.3 An invoice or Quote/Proforma Invoice for deposit purposes may be issued by Permaform to the Customer on placement of an order. Any applicable payment schedule will be duly noted on the documentation.
- 5.4 At Permaform's sole discretion a deposit may be required which:
 - (a) shall be assigned to the amount of the invoice if the order proceeds; or
 - (b) becomes non-refundable if the order does not proceed or is cancelled as per clause 14.2.
- 5.5 If any part of an invoice is in dispute then the Customer shall notify Permaform in writing within ten (10) business days once in receipt of the invoice, then the Customer may only withhold payment for that part of the invoice that is in dispute and shall pay the balance of the invoice when due.
- 5.6 Time for payment for the Goods being of the essence, the Price will be payable by the Customer on the date/s determined by Permaform, which may be:
 - (a) available for delivery defined as available for collection or delivery ex warehouse;
 - (b) by way of instalments/progress payments in accordance with Permaform's payment schedule;
 - (c) the date specified on any invoice or other form as being the date for payment; or
 - (d) failing any notice to the contrary, the date which is seven (7) business days following the date of any invoice given to the Customer by Permaform.

- 5.7 Payment may be made by electronic/on-line banking, or by any other method as agreed to between the Customer and Permaform.
- 5.8 Unless otherwise stated the Price does not include GST. In addition to the Price the Customer must pay to Permaform an amount equal to any GST Permaform must pay for any supply by Permaform under this or any other agreement for the sale of the Goods. The Customer must pay GST, without deduction or set off of any other amounts, at the same time and on the same basis as the Customer pays the Price. In addition the Customer must pay any other taxes and duties that may be applicable in addition to the Price except where they are expressly included in the Price.
- 5.9 The price quoted may be subject to change due to but not limited to change in supplier's costs, change in the cost of material and the currency fluctuations of the Australian Dollar. The price charged will be the price set by Permaform in accordance with Permaform's pricing policies and charges occurring prior to or at the date of collection/delivery. The project under construction may consist of a number of orders. The prices between these orders may vary.
- 5.10 Where Permaform has offered credit by way of an account with Permaform then Permaform, at its' sole and absolute discretion, may alter any offered Credit Limit to any amount including zero without notice and will confirm this in writing within 5 business days of the decision. Furthermore, Permaform will be entitled to demand immediate payment in full of any unpaid monies. If any invoice remains unpaid 7 days after such demand, then the Customer is in default and Permaform is entitled to commence all legal actions required to recover unpaid amounts.
- 5.11 Permaform may extend credit, to approved Customers, on a strict thirty (30) day basis from the end of the month in which the invoice is dated. Statements may be issued on the last day of each month. The customer must pay all amounts on all of the invoices within the payment terms.
- 5.12 Should any invoice due to be paid but remaining unpaid seven (7) calendar days after due date the account may be placed on "STOP CREDIT/TRADING" without notice to the Customer until the account is paid. Future Credit may be withdrawn at Permaform's unfettered discretion. Permaform reserves the right to report any default to its' Credit Reporting partners and Trade Credit partners.
- 5.13 Any account (invoice) in default (remains unpaid 7 days after due date) attracts a charge of 2.5% per month. This charge will be calculated on the full value of the invoice from due date (or part thereof being the daily rate of the month to 2 decimal places) until the invoice is paid in full. The 0.2% charge amount must be paid in full to lift a STOP CREDIT/TRADING status.
- 5.14 If Permaform's Trade Credit Insurer cancels or reduces the insurance offered on the Customer, then Permaform reserves the right to immediately terminate any Credit terms and demand immediate payment of any or all accounts (invoices) issued to the Customer.

6. Delivery of Goods

- 6.1 Delivery ("Delivery") of the Goods is taken to occur at the time that:
 - (a) the Customer or the Customer's nominated carrier takes possession of the Goods at Permaform's address; or
 - (b) Permaform (or Permaform's nominated carrier) delivers the Goods to the Customer's nominated address even if the Customer is not present at the address.
- 6.2 Where the Goods are delivered by a third party, the Customer is required to sign the delivery docket or any other form requiring acknowledgement of receipt of the Goods by the Customer immediately on delivery and these forms are to be given to the Delivery Driver for return to Permaform. If there is any dispute on the delivery quantities or condition of the goods, the Customer must state its dispute in writing with in within seven (7) days of the delivery date (see Clause 11). If the Customer fails to comply with clause 6.2 then Permaform reserves the right to deem the Goods are supplied as per the Delivery documentation and to be in satisfactory working order.
- 6.3 At Permaform's sole discretion the cost of delivery is either included in the Price or is in addition to the Price.
- 6.4 The Customer must take delivery by receipt or collection of the Goods whenever they are tendered for delivery. In the event that the Customer is unable to take delivery of the Goods as arranged then Permaform shall be entitled to charge a reasonable fee for redelivery and/or storage.
- 6.5 Any time or date given by Permaform to the Customer is an estimate only. The Customer must still accept delivery of the Goods even if late and Permaform will not be liable for any loss or damage incurred by the Customer as a result of the delivery being late.

7. Risk

- 7.1 Risk of damage to or loss of the Goods passes to the Customer on Delivery and the Customer must insure the Goods on or before Delivery.
- 7.2 If any of the Goods are damaged or destroyed following delivery but prior to ownership passing to the Customer, Permaform is entitled to receive all insurance proceeds payable for the Goods. The production of these terms and conditions by Permaform is sufficient evidence of Permaform's rights to receive the insurance proceeds without the need for any person dealing with Permaform to make further enquiries.
- 7.3 If the Customer requests Permaform to leave Goods outside Permaform's premises for collection or to deliver the Goods to an unattended location then such Goods shall be left at the Customer's sole risk.

8. Title

- 8.1 Permaform and the Customer agree that ownership of the Goods shall not pass until:
 - (a) the Customer has paid Permaform all amounts owing to Permaform; and
 - (b) the Customer has met all of its other obligations to Permaform.
- 8.2 Receipt by Permaform of any form of payment other than cash shall not be deemed to be payment until that form of payment has been honoured, cleared or recognised.
- 8.3 It is further agreed that:
 - (a) until ownership of the Goods passes to the Customer in accordance with clause 8.1 that the Customer is only a bailee of the Goods and must return the Goods to Permaform on request.
 - (b) the Customer holds the benefit of the Customer's insurance of the Goods on trust for Permaform and must pay to Permaform the proceeds of any insurance in the event of the Goods being lost, damaged or destroyed.
 - (c) the Customer must not sell, dispose, or otherwise part with possession of the Goods other than in the ordinary course of business and for market value. If the Customer sells, disposes or parts with possession of the Goods then the Customer must hold the proceeds of any such act on trust for Permaform and must pay or deliver the proceeds to Permaform on demand.
 - (d) the Customer should not convert or process the Goods or intermix them with other goods but if the Customer does so then the Customer holds the resulting product on trust for the benefit of Permaform and must sell, dispose of or return the resulting product to Permaform as it so directs.
 - (e) the Customer irrevocably authorises Permaform to enter any premises where Permaform believes the Goods are kept and recover possession of the Goods.
 - (f) Permaform may recover possession of any Goods in transit whether or not delivery has occurred.
 - (g) the Customer shall not charge or grant an encumbrance over the Goods nor grant nor otherwise give away any interest in the Goods while they remain the property of Permaform.
 - (h) Permaform may commence proceedings to recover the Price of the Goods sold notwithstanding that ownership of the Goods has not passed to the Customer.

9. Personal Property Securities Act 2009 ("PPSA")

- 9.1 In this clause financing statement, financing change statement, security agreement, and security interest has the meaning given to it by the PPSA.
- 9.2 Upon assenting to these terms and conditions in writing the Customer acknowledges and agrees that these terms and conditions constitute a security agreement for the purposes of the PPSA and creates a security interest in all Goods and/or collateral (account) – being a monetary obligation of the Customer to Permaform for Services – that have previously been supplied and that will be supplied in the future by Permaform to the Customer.
- 9.3 The Customer undertakes to:
 - (a) promptly sign any further documents and/or provide any further information (such information to be complete, accurate and up-to-date in all respects) which Permaform may reasonably require to;
 - (i) register a financing statement or financing change statement in relation to a security interest on the Personal Property Securities Register;
 - (ii) register any other document required to be registered by the PPSA; or
 - (iii) correct a defect in a statement referred to in clause 9.3(a)(i) or 9.3(a)(ii);
 - (b) indemnify, and upon demand reimburse, Permaform for all expenses incurred in registering a financing statement or financing change statement on the Personal Property Securities Register established by the PPSA or releasing any Goods charged thereby;
 - (c) not register a financing change statement in respect of a security interest without the prior written consent of Permaform;
 - (d) not register, or permit to be registered, a financing statement or a financing change statement in relation to the Goods and/or collateral (account) in favour of a third party without the prior written consent of Permaform;
 - (e) immediately advise Permaform of any material change in its business practices of selling the Goods which would result in a change in the nature of proceeds derived from such sales.
- 9.4 Permaform and the Customer agree that sections 96, 115 and 125 of the PPSA do not apply to the security agreement created by these terms and conditions.
- 9.5 The Customer waives their rights to receive notices under sections 95, 118, 121(4), 130, 132(3)(d) and 132(4) of the PPSA.
- 9.6 The Customer waives their rights as a grantor and/or a debtor under sections 142 and 143 of the PPSA.
- 9.7 Unless otherwise agreed to in writing by Permaform, the Customer waives their right to receive a verification statement in accordance with section 157 of the PPSA.
- 9.8 The Customer must unconditionally ratify any actions taken by Permaform under clauses 9.3 to 9.5.
- 9.9 Subject to any express provisions to the contrary (including those contained in clause 9), nothing in these terms and conditions is intended to have the effect of contracting out of any of the provisions of the PPSA.



1800 PERMAFORM

ABN 70 609 958 527

WWW.PERMAFORM.COM.AU

ORDERS@PERMAFORM.COM.AU

PERMAFORM INTERNATIONAL Pty Ltd

TERMS & CONDITIONS OF TRADE

10. Security and Charge

10.1 In consideration of Permaform agreeing to supply the Goods, the Customer charges all of its rights, title and interest (whether joint or several) in any land, realty or other assets capable of being charged, owned by the Customer either now or in the future, to secure the performance by the Customer of its obligations under these terms and conditions (including, but not limited to, the payment of any money).

10.2 The Customer indemnifies Permaform from and against all Permaform's costs and disbursements including legal costs on a solicitor and own client basis incurred in exercising Permaform's rights under this clause.

10.3 The Customer irrevocably appoints Permaform and each director of Permaform as the Customer's true and lawful attorney/s to perform all necessary acts to give effect to the provisions of this clause 10 including, but not limited to, signing any document on the Customer's behalf.

11. Defects, Warranties and Returns, Competition and Consumer Act 2010 (CCA)

11.1 The Customer must inspect the Goods immediately on delivery and must within seven (7) days of delivery and prior to installation, notify Permaform in writing of any evident defect/damage, shortage in quantity, or failure to comply with the description or quote. The Customer must notify any other alleged defect in the Goods as soon as reasonably possible after any such defect becomes evident. Upon such notification the Customer must allow Permaform to inspect the Goods.

11.2 Under applicable State, Territory and Commonwealth Law (including, without limitation the CCA), certain statutory implied guarantees and warranties (including, without limitation the statutory guarantees under the CCA) may be implied into these terms and conditions (Non-Excluded Guarantees).

11.3 Permaform acknowledges that nothing in these terms and conditions purports to modify or exclude the Non-Excluded Guarantees.

11.4 Except as expressly set out in these terms and conditions or in respect of the Non-Excluded Guarantees, Permaform makes no warranties or other representations under these terms and conditions including but not limited to the quality or suitability of the Goods. Permaform's liability in respect of these warranties is limited to the fullest extent permitted by law.

11.5 If the Customer is a consumer within the meaning of the CCA, Permaform's liability is limited to the extent permitted by section 64A of Schedule 2.

11.6 If Permaform is required to replace the Goods under this clause or the CCA, but is unable to do so, Permaform may refund any money the Customer has paid for the Goods.

11.7 If the Customer is not a consumer within the meaning of the CCA, Permaform's liability for any defect or damage in the Goods is:

- limited to the value of any express warranty or warranty card provided to the Customer by Permaform at Permaform's sole discretion;
- limited to any warranty to which Permaform is entitled, if Permaform did not manufacture the Goods;
- otherwise negated absolutely.

11.8 Subject to this clause 11, returns will only be accepted provided that the Customer has complied with the provisions of clause 11.1; and (b) Permaform has agreed that the Goods are defective; and (c) the Goods are returned within a reasonable time at the Customer's cost (if that cost is not significant); and (d) the Goods are returned in as close a condition to that in which they were delivered as is possible.

11.9 Notwithstanding clauses 11.1 to 11.8 but subject to the CCA, Permaform shall not be liable for any defect or damage which may be caused or partly caused by or arise as a result of:

- the Customer failing to properly maintain or store any Goods;
- the Customer using the Goods for any purpose other than that for which they were designed;
- the Customer continuing the use of any Goods after any defect became apparent or should have become apparent to a reasonably prudent operator or user;
- the Customer failing to follow any instructions or guidelines provided by Permaform;
- fair wear and tear, any accident, or act of God.

11.10 In the case of second hand Goods, unless the Customer is a consumer under the CCA, the Customer acknowledges that it has had full opportunity to inspect the second hand Goods prior to delivery and accepts them with all faults and that to the extent permitted by law no warranty is given by Permaform as to the quality or suitability for any purpose and any implied warranty, statutory or otherwise, is expressly excluded. The Customer acknowledges and agrees that Permaform has agreed to provide the Customer with the second hand Goods and calculated the Price of the second hand Goods in reliance of this clause 11.10.

12. Intellectual Property

12.1 Where Permaform has designed, drawn or developed Goods for the Customer, then the copyright in any designs and drawings and documents shall remain the property of Permaform.

12.2 The Customer warrants that all designs, specifications or instructions given to Permaform will not cause Permaform to infringe any patent, registered design or trademark in the execution of the Customer's order and the Customer agrees to indemnify Permaform against any action taken by a third party against Permaform in respect of any such infringement.

12.3 The Customer agrees that Permaform may (at no cost) use for the purposes of marketing or entry into any competition, any documents, designs, drawings or Goods which Permaform has created for the Customer.

13. Default and Consequences of Default (definition of Default?)

13.1 Interest on overdue invoices shall accrue daily from the date when payment becomes due, until the date of payment, at a rate of two and a half percent (2.5%) per calendar month (and at Permaform's sole discretion such interest shall compound monthly at such a rate) after as well as before any judgment.

13.2 If the Customer owes Permaform any money the Customer shall indemnify Permaform from and against all costs and disbursements incurred by Permaform in recovering the debt (including but not limited to internal administration fees, legal costs on a solicitor and own client basis, Permaform's contract default fee, and bank dishonour fees).

13.3 Further to any other rights or remedies Permaform may have under this contract, if a Customer has made payment to Permaform, and the transaction is subsequently reversed, the Customer shall be liable for the amount of the reversed transaction, in addition to any further costs incurred by Permaform under this clause 13 where it can be proven that such reversal is found to be illegal, fraudulent or in contravention to the Customer's obligations under this agreement.

13.4 Without prejudice to any other remedies Permaform may have, if at any time the Customer is in breach of any obligation (including those relating to payment) under these terms and conditions Permaform may suspend or terminate the supply of Goods to the Customer. Permaform will not be liable to the Customer for any loss or damage the Customer suffers because Permaform has exercised its rights under this clause.

13.5 Without prejudice to Permaform's other remedies at law Permaform shall be entitled to cancel all or any part of any order of the Customer which remains unfulfilled and all amounts owing to Permaform shall, whether or not due for payment, become immediately payable if:

- any money payable to Permaform becomes overdue, or in Permaform's opinion the Customer will be unable to make a payment when it falls due;
- the Customer becomes insolvent, convenes a meeting with its creditors or proposes or enters into an arrangement with creditors, or makes an assignment for the benefit of its creditors; or
- a receiver, manager, liquidator (provisional or otherwise) or similar person is appointed in respect of the Customer or any asset of the Customer.

14. Cancellation

14.1 Permaform may cancel any contract to which these terms and conditions apply or cancel delivery of Goods at any time before the Goods are delivered by giving written notice to the Customer. On giving such notice Permaform shall repay to the Customer any money paid by the Customer for the Goods. Permaform shall not be liable for any loss or damage whatsoever arising from such cancellation.

14.2 In the event that the Customer cancels delivery of Goods the Customer shall be liable for any and all loss incurred (whether direct or indirect) by Permaform as a direct result of the cancellation (including, but not limited to, any loss of profits).

14.3 Cancellation of orders for Goods made to the Customer's specifications, or for non-stocklist items, will definitely not be accepted once production has commenced, or an order has been placed.

15. Privacy Act 1988

15.1 The Customer agrees for Permaform to obtain from a credit reporting body (CRB) a credit report containing personal credit information (e.g. name, address, D.O.B, occupation, previous credit applications, credit history) about the Customer in relation to credit provided by Permaform.

15.2 The Customer agrees that Permaform may exchange information about the Customer with those credit providers and with related body corporates for the following purposes:

- to assess an application by the Customer; and/or
 - to notify other credit providers of a default by the Customer; and/or
 - to exchange information with other credit providers as to the status of this credit account, where the Customer is in default with other credit providers; and/or
 - to assess the creditworthiness of the Customer including the Customer's repayment history in the preceding two years.
- 15.3 The Customer consents to Permaform being given a consumer credit report to collect overdue payment on commercial credit.
- 15.4 The Customer agrees that personal credit information provided may be used and retained by Permaform for the following purposes (and for other agreed purposes or required by):
- the provision of Goods; and/or
 - analysing, verifying and/or checking the Customer's credit, payment and/or status in relation to the provision of Goods; and/or
 - processing of any payment instructions, direct debit facilities and/or credit facilities requested by the Customer; and/or
 - enabling the collection of amounts outstanding in relation to the Goods.

15.5 Permaform may give information about the Customer to a CRB for the following purposes:

- to obtain a consumer credit report;
- allow the CRB to create or maintain a credit information file about the Customer including credit history.

15.6 The information given to the CRB may include:

- personal information as outlined in 15.1 above;
- name of the credit provider and that Permaform is a current credit provider to the Customer;
- whether the credit provider is a licensee;
- type of consumer credit;
- details concerning the Customer's application for credit or commercial credit (e.g. date of commencement/termination of the credit account and the amount requested);
- advice of consumer credit defaults, overdue accounts, loan repayments or outstanding monies which are overdue by more than sixty (60) days and for which written notice for request of payment has been made and debt recovery action commenced or alternatively that the Customer no longer has any overdue accounts and Permaform has been paid or otherwise discharged and all details surrounding that discharge (e.g. dates of payments);
- information that, in the opinion of Permaform, the Customer has committed a serious credit infringement;
- advice that the amount of the Customer's overdue payment is equal to or more than one hundred and fifty dollars (\$150).

15.7 The Customer shall have the right to request (by e-mail) from Permaform:

- a copy of the information about the Customer retained by Permaform and the right to request that Permaform correct any incorrect information; and that Permaform does not disclose any personal information about the Customer for the purpose of direct marketing.

15.8 Permaform will destroy personal information upon the Customer's request (by e-mail) or if it is no longer required unless it is required in order to fulfil the obligations of this agreement or is required to be maintained and/or stored in accordance with the law.

15.9 The Customer can make a privacy complaint by contacting Permaform via e-mail. Permaform will respond to that complaint within seven (7) days of receipt and will take all reasonable steps to make a decision as to the complaint within thirty (30) days of receipt of the complaint. In the event that the Customer is not satisfied with the resolution provided, the Customer can make a complaint to the Information Commissioner at www.oaic.gov.au.

16. Building and Construction Industry (Security of Payment) Act 2009

16.1 At Permaform's sole discretion, if there are any disputes or claims for unpaid Goods and/or Services then the provisions of the Building and Construction Industry (Security of Payment) Act 2009 may apply.

16.2 Nothing in this agreement is intended to have the effect of contracting out of any applicable provisions of the Building and Construction Industry (Security of Payment) Act 2009 of the Australian Capital Territory, except to the extent permitted by the Act where applicable.

17. General

17.1 The failure by either party to enforce any provision of these terms and conditions shall not be treated as a waiver of that provision, nor shall it affect that party's right to subsequently enforce that provision. If any provision of these terms and conditions shall be invalid, void, illegal or unenforceable the validity, existence, legality and enforceability of the remaining provisions shall not be affected, prejudiced or impaired.

17.2 These terms and conditions and any contract to which they apply shall be governed by the laws of New South Wales and are subject to the jurisdiction of the courts in New South Wales.

17.3 Subject to clause 11, Permaform shall be under no liability whatsoever to the Customer for any indirect and/or consequential loss and/or expense (including loss of profit) suffered by the Customer arising out of a breach by Permaform of these terms and conditions (alternatively Permaform's liability shall be limited to damages which under no circumstances shall exceed the Price of the Goods).

17.4 The Customer shall not be entitled to set off against, or deduct from the Price, any sums owed or claimed to be owed to the Customer by Permaform nor to withhold payment of any invoice because part of that invoice is in dispute.

17.5 Neither party shall assign or sub-contract all or any part of their rights and obligations under this agreement without the written consent of the other party.

17.6 The Customer agrees that Permaform may amend these terms and conditions by notifying the Customer in writing. These changes shall be deemed to take effect from the date on which the Customer accepts such changes, or otherwise at such time as the Customer makes a further request for Permaform to provide Goods to the Customer.

17.7 Neither party shall be liable for any default due to any act of God, war, terrorism, strike, lock-out, industrial action, fire, flood, storm or other event beyond the reasonable control of either party.

17.8 Both parties warrant that they have the power to enter into this agreement and have obtained all necessary authorisations to allow them to do so, they are not insolvent and that this agreement creates binding and valid legal obligations on them.



PERMAFORM

QUICK ▶ STRONG ▶ STRAIGHT

PRODUCT CATALOGUE AND ORDERING CODES

AS AT APRIL 2019

PANEL (AP)

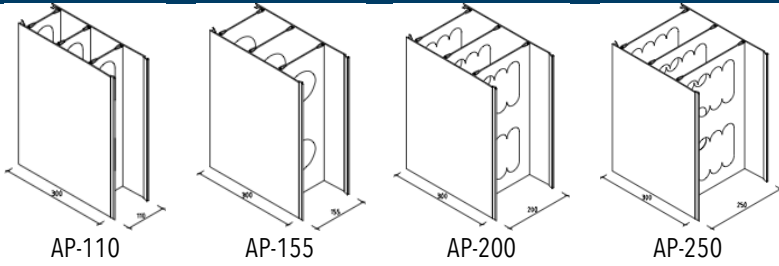

PANEL CONNECTOR (PC)

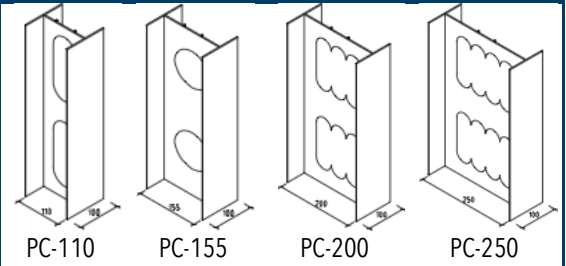

EDGE FLASHING (EF)

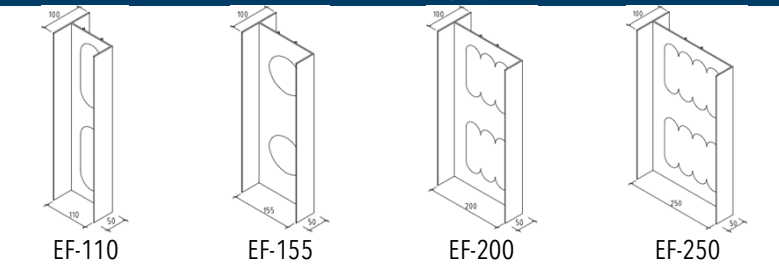

END CAP - MALE (ECM)

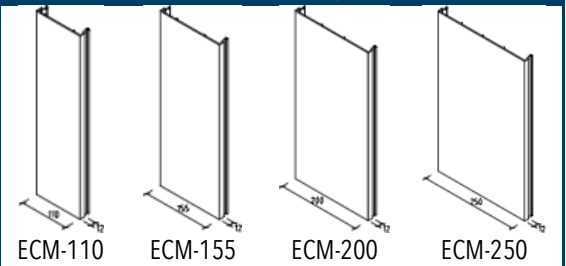

JUNCTION TRACK - FEMALE (JTF)

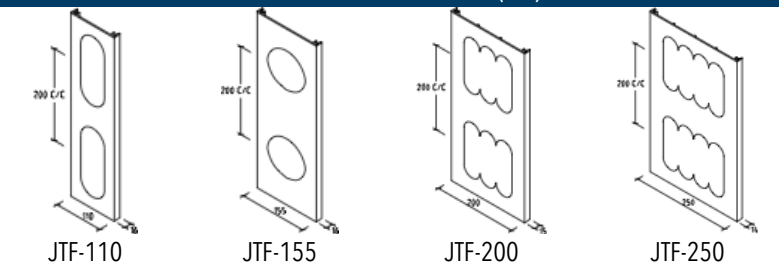

END CAP - FEMALE (ECF)

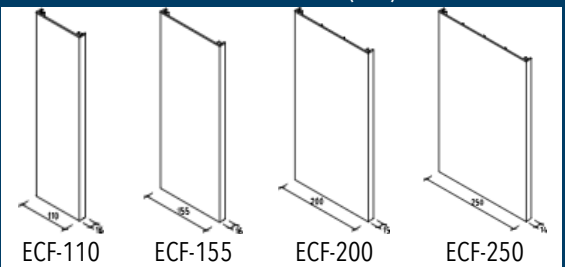

JUNCTION TRACK - MALE (JTM)

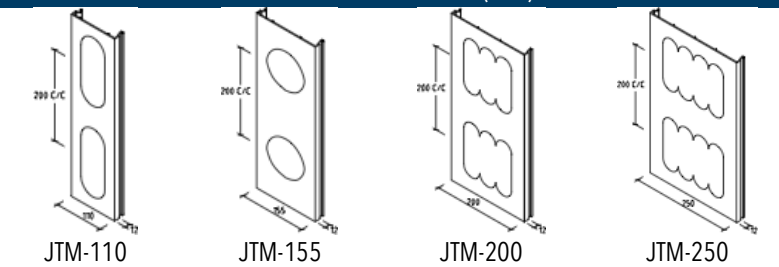

CORNER STOP

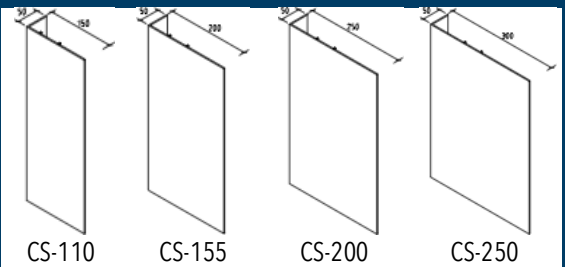

BOTTOM TRACK (BT)

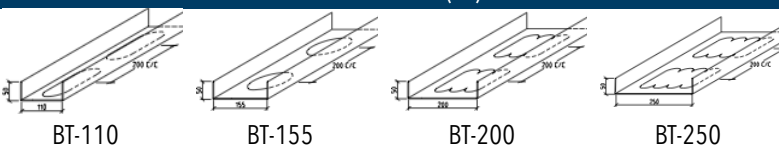

CORNER PANEL (CP)

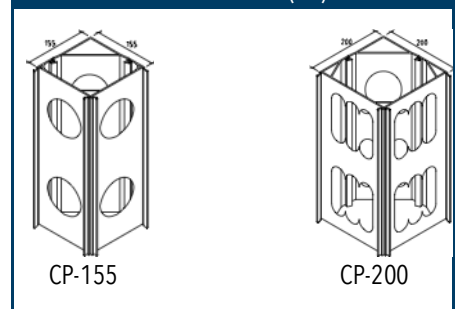

TOP CAP (TC)

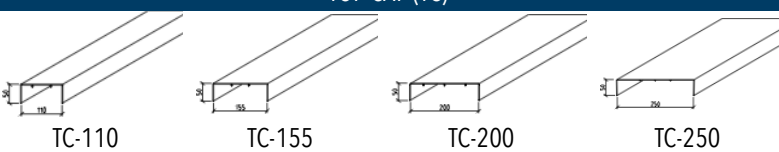

WALL INSTALLATION QUALITY ASSURANCE CHECKLIST



REF	DESCRIPTION	APPROVED			COMMENTS/REFERENCE/CONTACT
		YES	NO	N/A	
1	PRELIMINARIES				
A	Drawing transmittal date (Confirm all drawing numbers and revisions are correct)				
B	Wall quantities/heights/sizes approved by client				
C	Material supplied by: (eg installer/builder)				
D	All reinforcement supplied meets all drawing and specification requirements				
E	Concrete mix designs have been submitted and approved Provide mix code/number				
F	Concrete testing number: Test frequency: All concrete supplied meets all drawings and specification requirements				
G	Concrete supplier				
I	Concrete pump supplied by:				
J	Concrete pump size: Rego:				
2	PREPOUR CHECKLIST				
A	Wall survey supplied by				
B	Concrete footing flat and free of debris				
C	Bottom track installed correctly				
D	Water proofing/hydrophilic sealant installed correctly				
E	All walls installed in correct locations as per drawings and survey				
F	All penetrations locations provided and installed in accordance with site mark-out				
G	All walls have been installed straight and plumb				
H	No ribs/diaphragms are damaged, split or cracked				
I	All wall panels have been clipped in correctly with no visible gaps				
J	All finish wall heights have been installed as per drawings and specifications				
K	All corners and stop ends are adequately braced				
L	All window/door openings have been formed and braced correctly				
M	For walls above 4m: midway horizontal strongback to be screwed to panels and propped				
N	Props installed at a maximum spacing of 1.8m				
3	POUR CHECKLIST				
A	Max fill height 1500mm adhered to				
B	Concrete leaks are cleaned from walls and door frames				
C	Door frames remain plumb during pour process				
D	Window sills topped up and steel trowled				
E	All props secure and fixed and remain in situ in readiness of concrete slab above concrete pour				

PERMAFORM INSTALLER

NAME _____

SIGNATURE _____

DATE _____

AUTHORISED CLIENT REPRESENTATIVE

NAME _____

SIGNATURE _____

DATE _____